

PC-G1(TIANWU 50-233B)* Energy Storage System User Manual



Copyright © Jiangsu Weiheng Intelligent Technology Co., Ltd. All rights reserved.

Unauthorized excerpts, reproduction or distribution in any form, in whole or in part, of this document by any organization or individual without Jiangsu Weiheng Intelligent Technology Co., Ltd.'s written consent is strictly prohibited.

Trademark Statement

WHES and other trademarks are owned by Jiangsu Weiheng Intelligent Technology Co., Ltd. (herein after as WHES) All other trademarks or registered trademarks referenced herein are the property of their respective owners.

Note: Your purchase of the products, services or features is subject to WHES's commercial contracts and terms and conditions. As a result, all or part of the products, services or features described in this document may not be consistent with your specific purchase or use. Unless otherwise agreed in the contract, WHES makes no statements or warranties, express or implied, with respect to the contents of this document.

This document may be updated from time to time due to product version upgrades or other factors. Unless otherwise agreed, this document is provided as a guide only and no representations, information or recommendations contained herein constitute a warranty of any kind, either express or implied.

Jiangsu Weiheng Intelligent Technology Co., Ltd.

Address: Shengxiang, Yaxi Community, Luoshe Town, Huishan District, Wuxi, Jiangsu Province, China

Postal code: 214000

Website: www.whes.com

Introduction

Overview





This document provides guidance on the installation, electrical connection, commissioning, and troubleshooting methods for the WH-TIANWU-50-233B liquid cooled energy storage system (hereinafter referred to as the "energy storage system" or "ESS"). Prior to installation, operation of the energy storage system (ESS), please read this manual carefully, ensuring comprehension of the safety information and familiarity with the system's functions and features.

Readers

This manual is applicable to power station operators and qualified electrical technicians.

Symbol Convention

In this document, the following symbols may be used with the meanings described below.

Symbol	NOTE
	It indicates a hazard with a high level of risk that, if not avoided, will result in death or serious injury.
	It indicates a hazard with a moderate level of risk that, if not avoided, could result in death or serious injury.
	It indicates a hazard with a low level of risk that, if not avoided, could cause minor or moderate injury.
	It is used to convey warning information related to equipment or environmental safety. If not avoided, it may result in damage to equipment, loss of data, degradation of equipment performance, or other unpredictable consequences. The "BEWARE" symbol does not refer to personal injury.
	It is used to emphasize important/critical information, best practices, and tips. The "NOTE" symbol is not a safety warning and does not refer to personal injury, equipment damage, or environmental hazards.

Modification Record

The modification record tracks the description of all updates to the document. The latest version of the document contains all changes from previous revisions.

Document Version 01 (July 01, 2023)

V1.0

Document Version 02 (Oct 16, 2023)

V1.1

Changes: update the DC-side full-load voltage range. (500V→600V)

Document Version 03 (April 15, 2024)

V2.0

Changes: update the product appearance; add installation requirements; add F part-layout drawing

Document Version 04 (September 2, 2024)

V2.1

Changes: Updated the specifications of fire fighting equipment and dehumidification equipment.

Document Version 05 (August 1, 2025)

V3.0

Changes: Updated the equipment's appearance and refined the description of content related to energy storage system.

CONTENT

Introduction	i
1 Safety Precautions	1
1.1 General Safety.....	1
1.2 Personnel Requirements.....	6
1.3 Storage and Installation Environment Requirements.....	8
1.4 Loading/Unloading and Transport Requirements.....	11
1.5 Electrical Safety.....	13
1.6 Mechanical Safety.....	15
1.7 Battery Safety.....	17
1.8 Maintenance and Replacement.....	23
1.9 Emergency Procedures.....	24
2 Product Introduction	25
2.1 Model Description.....	25
2.2 Functions and Features.....	26
2.3. Appearance.....	27
2.4 Components.....	28
2.5. Working Principle.....	51
2.6 Compatible Grid Types.....	54
2.7 Application Scenarios.....	55
3 Site Requirements	57
3.1 Site Selection Requirements.....	57
3.2 Forklift Requirements.....	59
3.3 Lifting Requirements.....	60
4 Equipment Installation	61
4.1 Pre-Installation Preparation.....	61
4.2 Cable Selection.....	65
4.3 Installing the ESS and Cables.....	66
5 System Power-On/Off	73
5.1 Pre-Power-On Inspection.....	73
5.2 Circuit Breaker Description.....	75
5.3 Power-On Procedure.....	76
5.4 Power-Off Procedure.....	77

6 Power-On Commissioning (PANGU-LITE)78

6.1 Preparation and PANGU LITE Access 78

6.2 Screen Description..... 79

6.3 Startup Procedure..... 83

6.4 Shutdown Procedure.....85

7 Technical Data 86

8 Product Maintenance 87

8.1 Terminology Definition 87

8.2 Requirements for Normal System Operation 87

8.3 Requirements for Intermittent System Operation 87

8.4 Requirements for Long-Term System Storage 87

8.5 Isolating switch Function 88

8.6 Battery Maintenance Instructions.....88

8.7 Liquid Cooling System Maintenance and Service Requirements 89

A Crimping OT/DT Terminals91

B How to Repaint..... 94

C How to Recycle Used Batteries100

D Contact Details 101

E Abbreviations..... 102

F Layout Drawing103

G Energy Meter Configuration 107

Appendix 1 112

1 Safety Precautions

1.1 General Safety

Statement

Please thoroughly read this manual before installing, operating, and maintaining the equipment, and follow the markings present on the equipment, as well as all safety precautions outlined in this manual.

The "BEWARE", "CAUTION", "WARNING", and "DANGER" instructions contained in this manual do not cover all safety considerations that need to be observed, but are only intended to supplement all safety precautions. Whes disclaims any liability for damages resulting from failure to comply with general safe operation requirements or from violation of safety standards applicable to the design, production, and use of the equipment.

This equipment must be used in an environment that meets the design specifications, otherwise the equipment may fail, resulting in equipment malfunctions, component damage, personal safety accidents, property losses, etc., which are not covered by the quality warranty.

Be sure to install, operate and maintain the equipment in accordance with local laws, regulations, and specifications. The safety precautions contained in this manual are intended only to supplement local laws and regulations.

Whes shall not be held liable in any of the following circumstances:

- Installing or operating the equipment in an environment that exceeds applicable international, national, or local standards;
- Failure to operate the equipment under the conditions specified in this manual;
- Unauthorized disassembly, modification of the product or alteration of the software codes;
- Failure to operate the equipment in accordance with the operating instructions and safety warnings present on the product or outlined in the document;

- **Damage to the equipment caused by abnormal natural environment (force majeure, such as earthquake, fire, storm, flood, mudslide);**
- **Damage caused by the customer's failure to comply with transport and installation requirements;**
- **Damage caused by storage conditions not meeting the requirements specified in the product document;**
- **Damage to the hardware or data of the equipment due to customer negligence, improper operation or intentional damage;**
- **Damage to the system caused by third parties or customers, including relocation and installation of the system not in accordance with the requirements of this manual, and adjustment, modification, or removal of identification marks not in accordance with the requirements of this manual;**
- **Defects, failures or damage caused by acts, events, negligence or accidents beyond the reasonable control of the Seller, including power outages or electrical failures, theft, war, riots, civil commotion, terrorism, intentional or malicious damage, etc.**

General Requirements



The equipment operates at high voltages and improper handling poses a risk of electric shock or fire, which may cause death, serious injury, or substantial property damage. Always operate according to instructions:

- **Follow the operating procedures and safety precautions described in this manual and other relevant documents.**
- **Follow warning labels, cautions, and protective measures affixed to the equipment.**
- **Use the correct tools as specified in this manual and be proficient in the proper use of the tools.**
- **Comply with the safety regulations of the power plant, such as implementing the operation ticket and work ticket system.**
- **No one except the operator is allowed to access the equipment. Temporary warning signs or fencing must be erected to isolate the area during operation of the equipment.**
- **All warning labels, cautions, and protective measures affixed to the equipment shall remain legible. Unauthorized alteration, damage, or obstruction of such safety information is strictly prohibited. Any illegible markings shall be replaced in a timely manner.**

- **Do not perform installation, wiring, maintenance, and replacement operations while the equipment is powered on.**
 - **Do not clean the electrical components inside the equipment with water.**
 - **Check the equipment for damage, such as holes, dents or other signs of possible internal damage.**
 - **Check that the pre-installed cables of the equipment are securely connected.**
 - **Check that the equipment is free from displacement of internal components, or unauthorized modification of internal structure and installation procedures.**
 - **Do not power on the equipment until it has been installed or approved by qualified personnel.**
 - **Measure the voltage at the contact point before touching any conductor surface or terminal, and confirm that the protective grounding conductor of the equipment or parts to be repaired is securely grounded to ensure that there is no risk of electric shock.**
 - **Immediately press the EMERGENCY STOP switch and notify the on-site management if any liquid ingress is detected in the equipment.**
 - **Do not open the cabinet door while the system is operating.**
 - **Wear arc-resistant clothing when powering on the equipment for the first time or working on the live main circuit.**
-

 CAUTION

- Do not perform arc welding, drilling, or cutting operations on the equipment. Such operations may damage the sealing of the entire enclosure, the electromagnetic shielding performance of the equipment, the internal components and cables, and the metal chips generated during the operation may cause short circuits, affecting the equipment function or causing equipment damage.
- The casing temperature is elevated during operation of the equipment, posing a risk of burns. Avoid physical contact with the equipment.
- If, during operation of the equipment, a fault is detected that may cause personal injury or damage to the equipment, stop operation immediately, notify the person in charge, and take effective protective measures.
- Evacuate the area immediately if an audible/visual fire alarm is activated.
- Close and lock the cabinet door if the equipment has to be left temporarily unattended during the maintenance procedure.

 BEWARE

- All transport, transit, installation, wiring, and maintenance activities must comply with the applicable laws, regulations, and standards of the country/region where the work is performed.
- The materials to be prepared by the user and the tools required during operation must comply with the applicable laws, regulations, and standards of the country or region where the work is performed.
- Permission from the local power authority must be obtained before the equipment is connected to the grid.
- Before opening the cabinet door during installation, operation, and maintenance, be sure to remove any accumulated water, snow, or other debris from the top of the enclosure to prevent debris from falling into the enclosure.

 NOTE

- **It is prohibited to reverse engineer, decompile, disassemble, dismantle, adapt, implant, or perform other derivative operations on the equipment software. It is not allowed to research the internal implementation of the equipment, obtain the source code of the equipment software, or steal intellectual property rights in any way, nor is it allowed to disclose the results of any performance tests of the equipment software.**
- **It is recommended that users prepare video recording devices to document the detailed process of installation, operation, and maintenance of the equipment.**

1.2 Personnel Requirements

 **BEWARE**

- Only qualified personnel are permitted to perform tasks related to the equipment, including transport, transit, installation, wiring, and maintenance. When operating the equipment, operators must wear personal protective equipment that complies with local safety requirements.
- Operators must have completed Whes's relevant training programs, passed the required examinations, and demonstrated professional knowledge of the ESS.

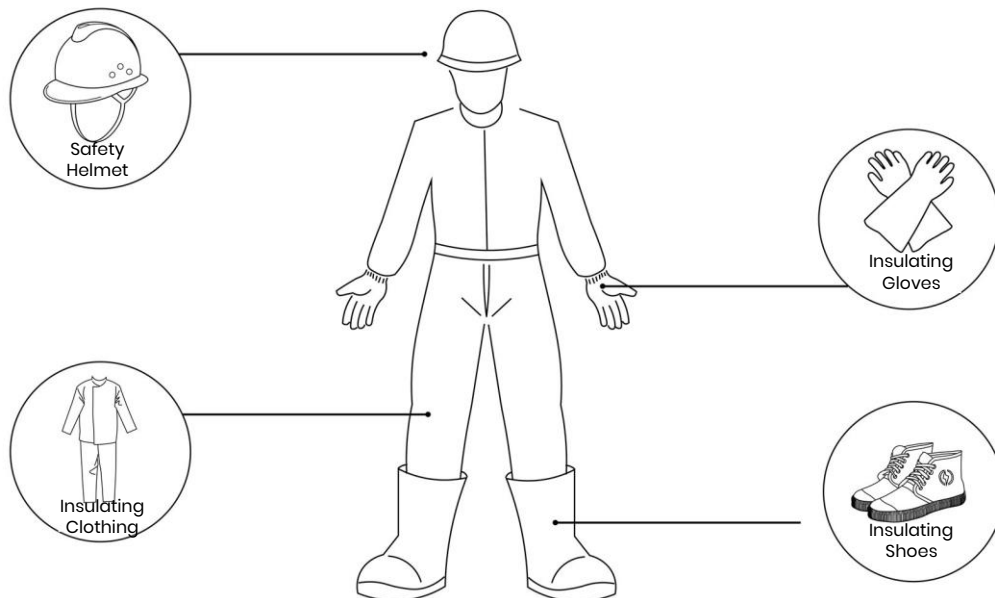

 **Figure 1-1 Illustration of Personal Protective Equipment**

 NOTE

- **Local regulations and industry standards shall be consulted for specific qualification requirements.**
- **Do not wear watches, bracelets, bangles, rings, necklaces, or other conductive items during installation, operation, or maintenance to prevent electric shock and burns.**
- **All transport, transit, installation, wiring, and maintenance activities must comply with the applicable laws, regulations, and standards of the country/region where the work is performed.**
- **It is important to ensure a comprehensive understanding of the construction and working principle of the entire AC control cabinet, and conduct all activities in accordance with the instructions provided in this manual.**

1.3 Storage and Installation Environment Requirements

General requirements

 **NOTE**

- During the storage period, relevant evidence demonstrating compliance with product storage requirements, including temperature and humidity logs, photos of the storage environment, and inspection reports, must be properly maintained.
- The storage environment must be maintained in a clean and dry condition to prevent dust and moisture contamination. The equipment shall be protected from exposure to rain or groundwater.
- The ambient air must not contain any corrosive or flammable gases.
- Do not store the equipment in a tilted or inverted position.
- Equipment that has been stored for two years or more shall be inspected and tested by qualified personnel before being put into use.

Control Cabinet Storage Requirements

 **NOTE**

- Stacking storage is prohibited.
- Store the equipment on a level surface (for long-term or temporary storage).
- Keep the cabinet door securely closed.
- Storage temperature: $-30^{\circ}\text{C} \sim +60^{\circ}\text{C}$, humidity: 5%RH~95%RH.
- Avoid direct sunlight or rain, maintain a dry and well-ventilated environment, keep the surrounding area clean, and ensure that the equipment is located away from sources of intense infrared radiation, organic solvents, corrosive gases, and ignition.
- The warehouse keeper shall be responsible for making monthly statistics of the All-in-One Energy Storage System inventory and reporting them to the planning department on a regular basis.
- Stored All-in-One Energy Storage System must be shipped based on the "first in, first out" principle.

Installation Environment Requirements

For site selection, please refer to [3.1 Site Selection Requirements](#). The following requirements must also be met during on-site installation:

- The installation layout of the ESS must meet the local standard requirements for fire protection distance or fire walls, including but not limited to the requirements of GB 51048-2014: Design Code for Electrochemical Energy Storage Power Station and NFPA 855 Standard for the Installation of Stationary Energy Storage Systems.
- It is prohibited to place the equipment in an environment with flammable, explosive gases, or smoke, and to operate the equipment in such an environment.
- The installation, use, and operation of outdoor equipment and cables (including but not limited to moving equipment, operating equipment and cables, plugging and unplugging outdoor signal interfaces, working at heights, and outdoor installation) is prohibited during thunderstorms, rain, snow, and winds of level 6 or above.
- It is recommended to install fences, walls, and other protective measures around the ESS, and erect safety warning signs to isolate the area and prevent unauthorized personnel from accessing the equipment during operation, which may result in personal injury or property damage.
- Do not block the vents and the cooling system during operation of the equipment to prevent fires caused by high temperatures.
- The equipment shall be installed in an area free from liquids and away from locations prone to condensation (such as under water pipes and air outlets) or prone to potential water leakage (such as under air conditioners, vents, and machine room cable exit windows) to prevent liquid from entering the equipment and causing faults or short circuits.
- The installation site must be located away from sources of ignition, and no flammable or explosive materials shall be placed in the vicinity of the equipment.
- If the equipment is installed in an area with lush vegetation, periodic weeding and hardening of the soil beneath the equipment is required to prevent weed growth.

Requirements for Working at Heights

- **Implement proper safety protection measures, including using safety helmets, safety harnesses, waist safety belts, and attaching them to robust and reliable structural members. Do not hang them on moving unstable objects or sharp-edged metals, to prevent the hook from slipping and causing a fall accident.**
- **The elevated work site must be clearly designated as a restricted, hazardous area with prominent markings to deter unauthorized access.**
- **The ground area directly beneath the elevated work zone must be kept clear of any stacked scaffolding, planks, or other debris. Ground personnel are prohibited from staying or passing directly below the high-altitude operation area.**
- **Do not throw objects from a high place to the ground or vice versa. All items must be transported using appropriate methods such as ropes, hanging baskets, overhead vehicles, or cranes.**
- **All scaffolding, planks, and work platforms utilized for elevated work must undergo a thorough safety inspection and certification prior to use, ensuring structural reliability and preventing scaffold overloading.**
- **Elevated work must be immediately suspended during rain or other potentially hazardous conditions. Thereafter, Whes's safety supervisor and relevant technicians must inspect all equipment and give approval before elevated work can be safely resumed.**
- **All edges and openings within the elevated work zone shall be outfitted with guardrails and markings to prevent the risks of accidental falls or step-through incidents.**
- **Securely carry all necessary apparatus and tools during operations to prevent accidental falls.**
- **If an elevated worker is found to be violating safety protocols and performing construction work improperly, the site supervisor or safety officer must immediately issue a warning and instruct the worker to make corrections. Work may not be resumed until the elevated worker is in full compliance with established operating specifications.**

1.4 Loading/Unloading and Transport Requirements

BEWARE

This product has been certified to comply with UN38.3 (UN38.3: Section 38.3 of the sixth Revised Edition of the Recommendations on the Transport of Dangerous Goods: Manual of Tests and Criteria) and SN/T 0370.2-2009 Rules for the Inspection of Packing for Export Dangerous Goods - Part 2: Performance Test, and is consequently classified as a Class 9 Dangerous Good.

Shipment conditions:

Energy storage battery cabinets must be inspected prior to shipment to ensure that the enclosure is intact and undamaged, the cabinet doors are properly closed and locked, no foreign objects are protruding from the interior, and no indications of smoke or burning are present. Failure to meet any of these criteria will result in the shipment being prohibited.

NOTE

- The control cabinet must be inspected prior to shipment to ensure that the enclosure is intact and undamaged, the cabinet doors are properly closed and locked, no foreign objects are protruding from the interior, and no indications of smoke or burning are present. Otherwise, shipment is prohibited.
- During loading/unloading and transport, care should be taken to handle gently and provide moisture protection measures. Due to the influence of external environmental factors (such as temperature, transport and storage conditions), the product specifications are subject to the date of manufacture.
- The AC control cabinet is not intended for railway or air transport methods.
- For sea transport, the International Maritime Dangerous Goods Code (IMDG) must be observed.
- For land transport, the requirements of the Authorization Dangerous Road (ADR) or JT/T 617-2018: Regulations concerning Road Transportation of Dangerous Goods must be followed.
- Comply with the regulatory requirements set forth by the transport authorities in the countries of origin, transit, and destination.
- Comply with international transport rules for dangerous goods and the regulatory requirements set forth by the transport authorities in relevant countries.
- Monitoring is required throughout the entirety of the transport process.

- Vehicles used for land transport must have sufficient load capacity (ESS weight: approximately 2500 kg per unit).
 - The speed limit for land transport is 80km/h on flat roads and 60km/h on rugged roads, with local traffic regulations taking precedence if they conflict with these guidelines.
 - Stacking is prohibited during port handling and on-board transport. The following situations are strictly prohibited during transport: falling into water, dropping or mechanical impact, as well as inverting or overturning.
-

 NOTE

1. The energy storage battery cabinet falls or is mechanically impacted.
2. The energy storage battery cabinet is inverted or overturned.

If the above situation occurs, follow the emergency procedures in Section 1.8.

1.5 Electrical Safety

Wiring Requirements



NOTE

- It is prohibited to push the cables off the vehicle in an improper manner such as directly dropping them.
- Do not route cables through the air inlet/outlet of the equipment.
- Cables of the same type shall be bundled together, while cables of different types shall be spaced at least 30 mm apart without intertwining or crossing.
- If the site has to be left unattended temporarily after or during the wiring process, the cable openings must be immediately sealed using sealing mud to prevent the ingress of small animals.
- Cables used in high-temperature environments are susceptible to insulation aging and damage. A minimum clearance of 30 mm must be maintained between cables and heat-generating components or heat source peripheries.
- Select cables that are in compliance with local laws and regulations.
- Cable troughs and openings must be free of sharp edges and provided with appropriate protection.
- Cable conduits or openings shall be protected against damage from sharp edges or burrs.
- Cables used in the ESS must be firmly connected, well-insulated, and comply with the appropriate specifications.
- After wiring, the cables must be securely fixed using cable supports and clamps. For cables in backfilled soil areas, ensure they are in close contact with the ground to prevent deformation or damage during backfilling.
- At low temperatures, violent impact and vibration may cause the outer plastic sheath of the cables to become brittle and crack. To ensure construction safety, the following requirements shall be followed:
 1. All cables must be laid and installed at temperatures above 0°C. Care should be taken when handling cables, especially in low-temperature environments.
 2. If cables are stored at temperatures below 0°C, they must be placed at room temperature for at least 24 h prior to installation.

Grounding Requirements

- Do not damage grounding conductors.
- Do not operate the equipment without installed grounding conductors.
- The main grounding body of the equipment must be permanently connected to the protective grounding network. Before operating the equipment, the electrical connection must be checked to ensure reliable grounding.
- The grounding impedance of the equipment shall meet the requirements specified in GB 50054-2011 and any applicable local electrical standards.

AC/DC Operation Requirements

- Before installing or removing the power cord, turn off the power switch first.
- Prior to connecting the power cord, verify that the label on the power cord is correct.
- If the equipment has multiple inputs, all inputs shall be disconnected and the equipment shall be completely de-energized before any work is performed.

Operation, Maintenance and Repair Safety Requirements

- Turn off the circuit breaker before connecting or disconnecting any cables.
- Place a "Do Not Close" warning sign on the open switch.
- Use a voltage tester of the appropriate rating to verify the equipment is completely de-energized.
- Cover or wrap any nearby live parts with insulating sheeting or tape.
- Before performing any operation, maintenance or repair activities, connect the circuit to be repaired securely to the grounding circuit using a grounding wire.



- Prior to connecting cables, verify that the label on the cable is correct.
 - If the equipment has multiple inputs, all inputs should be disconnected and the equipment should be completely de-energized before any work is performed.
-
- After the repair is completed, remove the grounding wire between the repaired circuit and the grounding circuit.

1.6 Mechanical Safety

Transport Safety



- This equipment must be lifted using a lifting frame.
- When using a forklift to move the equipment, ensure that the forklift has sufficient load capacity and that the center of gravity of the equipment is between the forklift legs to prevent personal injury and equipment damage;
- Forklift load capacity: ≥ 5 t;
- Recommended fork length: ≥ 1.8 m, fork width: 60cm~80cm, fork thickness: 25 mm~70 mm.

Safety Instructions for Ladder Use

- Using straight ladders is prohibited.
- Before using a ladder, ensure it is in good condition and the load capacity meets the requirements. Overloading is strictly prohibited.
- Use wooden or fiberglass ladders when working overhead where electricity may be involved.
- When working overhead, it is preferable to use platform ladders with guardrails, where all four feet are securely fixed and the ladder is held by one person.

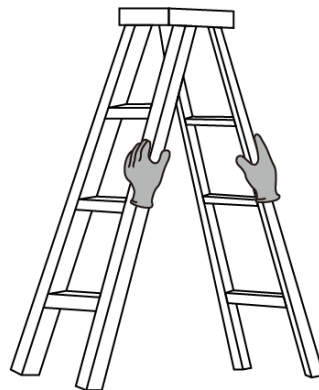

Figure 1-2 Holding Ladder

- When climbing a ladder, please pay attention to the following actions to reduce danger and ensure safety.

CAUTION

- **Maintain a stable body posture.**
- **Stand on the ladder without exceeding the 4th rung from the top.**
- **Ensure your center of gravity remains within the ladder frame.**

Equipment Exterior Drilling Safety

- **Before drilling, carefully select the drilling location to avoid short circuits or other adverse effects.**
- **Wear safety goggles, gloves and other personal protective equipment when drilling.**
- **Effectively shield the equipment during drilling to prevent ingress of debris, and clean and remove debris promptly afterward.**

Safety Instructions for Handling Heavy Objects

- **When handling heavy objects, arrange for the number of people recommended in the diagram to ensure collaborative operation and load sharing.**

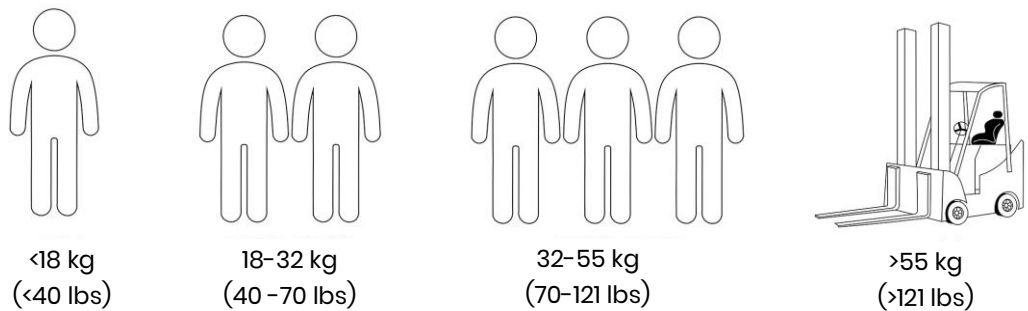

Figure 1- 4 Installation Personnel Requirements

- **Wear protective gloves, anti-smash anti-puncture safety shoes and other personal protective equipment when handling the equipment by hand.**
- **Protect the equipment from surface scratches or damage to internal components/cables during handling.**
- **For forklift handling, ensure the forks are centered under the load to prevent tipping. Secure the equipment to the forklift with ropes before moving, and assign a dedicated person to monitor during movement.**
- **Move the equipment carefully to avoid collisions or falls.**

1.7 Battery Safety

i Notice

The WH-TIANWU-50-233B energy storage system is specifically designed to integrate with the battery chemistry of lithium-iron-phosphate packs.

Statement

Whes will not be liable for damage to the battery supplied by Whes due to the following reasons:

- Battery capacity loss or irreversible damage caused by the customer's failure to charge the battery in a timely manner, resulting in expired storage.
- Damage to the battery caused by the customer's failure to accept the battery in a timely manner;
- Failure by the customer to properly set the system operation and management strategy, resulting in battery performance degradation;
- Unauthorized changes to the battery pack application scenario by the customer or a third party without prior notification to Whes, such as unauthorized connection of additional loads to the battery pack, and mixing the original battery pack with others, including different brands or varying rated capacities;
- Damage to the battery pack caused by the equipment operating environment or external power parameters failing to meet the normal operating requirements, including excessively high or low actual temperatures;
- Improper maintenance by the customer resulting in frequent over-discharge of the battery, capacity extension on site by the customer or long-term inability to fully charge the battery, etc.
- Failure by the customer to properly maintain the battery in accordance with the supplied equipment operating manual, including but not limited to ensuring the integrity of the cooling system, and addressing any loose or damaged HV cable harness or loose or missing structural fixing bolts;
- Theft of battery packs;
- Battery packs beyond the warranty period.

Basic Requirements



- **Do not expose the battery pack to high temperatures or near heating devices, such as direct sunlight, fire sources, transformers, heaters, etc. Overheating of the battery pack may cause fire or explosion hazards.**
- **Do not disassemble, modify, or damage the battery pack in any way (e.g. by inserting foreign objects, immersing in water or other liquids) to prevent battery pack leakage, overheating, fire or explosion.**
- **Lithium-ion battery energy storage systems pose a high risk of fire. Before performing any battery-related operations, it is essential to thoroughly consider the following safety risks:**
 1. **The electrolyte in the battery pack is flammable, toxic, and volatile.**
 2. **Thermal runaway of the battery pack may generate flammable and harmful gases such as carbon monoxide and hydrogen fluoride.**
 3. **The accumulation of flammable gases from thermal runaway of the battery pack poses a risk of combustion and explosion.**
- **The battery pack shall be stored with its original outer packaging in a dedicated warehouse, separated from other materials. Outdoor storage is prohibited. The stacking height must be maintained within safe limits. Fire fighting facilities, such as fire sand and fire extinguishers, must be provided on site in accordance with regulations.**
- **For outdoor applications, it is recommended to charge an unpacked battery pack within 24 h. If timely charging is not possible, the battery pack shall be stored in a dry, indoor environment free of non-corrosive gases.**
- **Under normal circumstances, do not remove the outer packaging of the battery pack. Recharging, if necessary, must be performed by qualified personnel as per the specified requirements. The battery pack must be properly repackaged upon completion of recharging.**
- **The battery pack shall be properly oriented according to the anti-inversion label or marking on the packaging to prevent cell leakage from prolonged inverted storage.**
- **The ESS shall be subject to regular fire safety inspections, at least once a month.**

- Use the battery pack only within the temperature range specified in this manual. Do not charge the battery pack when the ambient temperature is below the lower operating limit to prevent crystallization and internal short circuits.
- The battery pack must be protected from impacts.
- The storage location for damaged battery packs must be free of flammable materials, with access restricted to unauthorized personnel. During storage, damaged battery packs shall be monitored for signs of smoke, flames, electrolyte leakage, or heating.
- The battery pack that has been accidentally exposed to water must not be installed, but must be transported to a safe, isolated location for timely replacement with spare parts.
- The storage area must be protected from direct sunlight and rain, and must be dry, well ventilated, clean, and free from excessive infrared/ionizing radiation, organic solvents, and corrosive gases.
- Dispose of used battery packs in accordance with local laws and regulations. Do not treat them as household waste to prevent environmental contamination.
- Do not use damaged battery packs (such as dents or other damage on the casing), as damaged battery packs may release flammable gases and shall not be stored near undamaged products.

Recharging Requirements

Whes will not be liable for damage to the battery supplied by Whes due to the following reasons:

- After delivery, if the Product does not run or has been shut down for more than three months, the capacity SOC is lower than 50%, causing serious battery attenuation;
- Recharging is mandatory if the battery cabinet has not been charged for more than 5 months. Failure to adhere to the recharging schedule may compromise the performance and lifetime of the battery cabinet.
- The production completion date of the battery cabinet can be determined by querying the shipment records using the battery cabinet serial number (SN) or by consulting Whes's service engineer

Battery Pack Installation Requirements

 NOTE

Before installing the battery pack, check it for abnormalities. Battery pack abnormalities include the following:

- The battery pack casing exhibits visible deformation or damage;
- The total voltage between the positive and negative terminals of the battery pack is significantly lower than the specified range.
- Use only the specified battery pack model. Use of non-specified models may result in damage to the battery cabinet.
- Before installing the battery pack, check whether the packaging is intact. Battery packs with damaged packaging must not be used.
- The battery pack must be placed horizontally and secured.
- Do not place any installation tools or debris on the battery pack during installation.
- When installing the battery pack, it is important to properly connect the positive and negative terminals. Short-circuiting the positive and negative terminals of the battery pack is strictly prohibited.
- When installing the battery pack, use a torque wrench to ensure that the terminals are tightened securely. Check the terminals on a regular basis for signs of loosening.

Battery Pack Short-Circuit Protection

 DANGER

A short circuit in the battery pack may generate a large current surge and release significant energy, posing a serious risk of personal injury and property damage.

- When installing and maintaining the battery pack, use insulating tape to wrap the exposed wire terminals on the battery pack.
- Prevent foreign objects (such as conductive objects, screws, and liquids) from entering the battery pack and causing short circuits.

Hazard and Toxicity Information



- **Hazard:** A damaged battery pack may cause overheating or electrolyte leakage. Electrolyte is flammable. If leakage occurs, immediately move the battery cabinet away from any heat source.
 - **Toxicity:** Vapors from a burning battery pack may cause irritation to the eyes, skin, and throat.
-

Countermeasures for Abnormal Battery Packs



- In case of electrolyte leakage or an unusual odor, avoid contact with the leaking liquid or gas. Access shall be restricted to unauthorized personnel. Contact qualified personnel immediately for proper handling. Professionals must wear personal protective equipment, including goggles, rubber gloves, a gas mask, and protective clothing to protect against possible hazards caused by electrolyte spillage.
 - Electrolyte is corrosive and may cause skin irritation and chemical burns. In case of exposure to electrolyte, the following measures must be taken:
 - **Inhalation:** Evacuate the contaminated area, provide fresh air, and seek medical attention immediately.
 - **Eye contact:** Immediately flush eyes with plenty of water for at least 15 min, without rubbing the eyes, and seek medical attention.
 - **Skin contact:** Immediately wash the affected area with soap and water, and seek medical attention.
 - **Ingestion:** Seek medical attention immediately.
-

Battery Pack Drop Incident

- If the battery pack falls (with or without packaging) but shows no visible deformation or damage, and no noticeable odor, smoke, or fire, proceed with caution and safety in mind as follows:
 - Warehouse: Evacuate personnel, use mechanical tools to transfer the battery pack to a safe, open area by qualified personnel, and contact Whes's service engineers. Allow the battery pack to rest for 1 h and monitor the temperature to ensure it remains within ambient temperature $\pm 10^{\circ}\text{C}$ before further proceeding.
 - ESS site: Evacuate personnel, close the ESS door, use mechanical tools to transfer the battery pack to a safe, open area by qualified personnel, and contact Whes's service engineers. Allow the battery pack to rest for 1 h before further proceeding.
- If the battery pack exhibits a noticeable odor, damage, smoke, or fire after a drop, immediately evacuate personnel, contact professionals, and promptly call emergency services. Professionals should use firefighting equipment to extinguish the fire while ensuring safety.
- Do not continue to use a dropped battery pack. Contact Whes's service engineers for evaluation.

1.8 Maintenance and Replacement

 **CAUTION**

Before removing any component from the cabinet, verify that all other components are securely fastened.

- A minimum of two people is required on site during ESS maintenance.
- During equipment maintenance, always use insulating materials to cover nearby live components.
- Do not open the cabinet door in severe weather conditions such as rain, snow, lightning, sandstorms, or heavy fog.
- Never allow objects (such as fingers, components, screws, or tools) to come into contact with a running fan before it is powered off or stops rotating.
- Do not power on the equipment before troubleshooting.
- During live system patrol inspections, observe hazard warnings on the equipment and avoid standing near the cabinet door.
- After shutting down the equipment other than the battery packs, wait 15 min to ensure complete de-energization before proceeding with any operation on the equipment.
- A "Do Not Close" warning sign must be displayed on any switch that is disconnected for maintenance.
- After replacing power components or changing wiring in the ESS, manually initiate wiring detection and topology identification to prevent system malfunctions.
- Lock the cabinet door, secure the safety cable, and keep the key in a safe location immediately after completing maintenance and replacement.

1.9 Emergency Procedures

In the event of an incident, including but not limited to those listed below, immediately take appropriate measures to ensure the safety of all personnel on site, and contact Whes's service engineers.

In Case of Fire



Recommendations for on-site operation and maintenance personnel:

1. In case of fire, evacuate the building or equipment area and activate the fire alarm bell. Call the fire department immediately to notify professional firefighters and provide them with relevant product information.
2. Never re-enter the burning building or equipment area, or open the door of the AC control cabinet. Isolate and monitor the site, and restrict access to unauthorized personnel.
3. After contacting the fire department, remotely shut down the system while prioritizing your own safety.
4. Upon the arrival of professional firefighters, provide them with relevant product information.
5. Once professional firefighters confirm the fire is extinguished, allow qualified personnel to handle the situation according to local regulations. Do not open the door of the AC control cabinet without authorization.
6. Post-disaster product maintenance: Contact Whes's service engineers for evaluation.

Recommendations for fire professionals:

1. Refer to the product information provided by the operation and maintenance personnel.
2. Do not open the door of the AC control cabinet if the internal safety of the cabinet cannot be guaranteed.
3. Please follow local fire regulations for fire extinguishing operations.

2 Product Introduction

2.1 Model Description

Product Model Description:

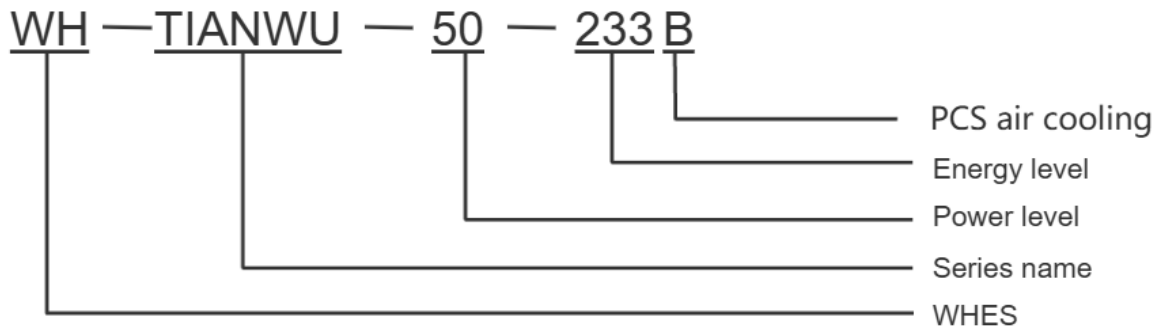

This document primarily focuses on the following product models:

WH-TIANWU-50-233B

2.2 Functions and Features

Function

The WH-TIANWU-50-233B energy storage system supports grid-connected operation mode.

- **Grid-connected mode**

The AC side of the energy storage system is connected to the grid, while the DC side is internally connected to the battery pack. It can be widely used for capacity expansion, PV-ESS-charging, peak shaving and other applications. Depending on the selected operation mode, the lithium-ion batteries can be charged and discharged under constant voltage, constant current, or constant power conditions.

Features

The energy storage system integrates the power distribution system, monitoring system, environmental control system, and fire suppression system, featuring improved safety, enhanced reliability, rapid deployment, low cost, high energy efficiency, and intelligent management.

- **Cluster-by-cluster optimization and cluster-level energy management, avoiding parallel circulating current issues in battery clusters;**
- **Standardized modular design, allowing for on-demand assembly, easy maintenance, and convenient capacity expansion;**
- **Liquid-cooled battery design, ensuring high energy density, compact footprint, and consistent cell temperatures.**
- **Support multi-unit parallel operation.**

2.3. Appearance

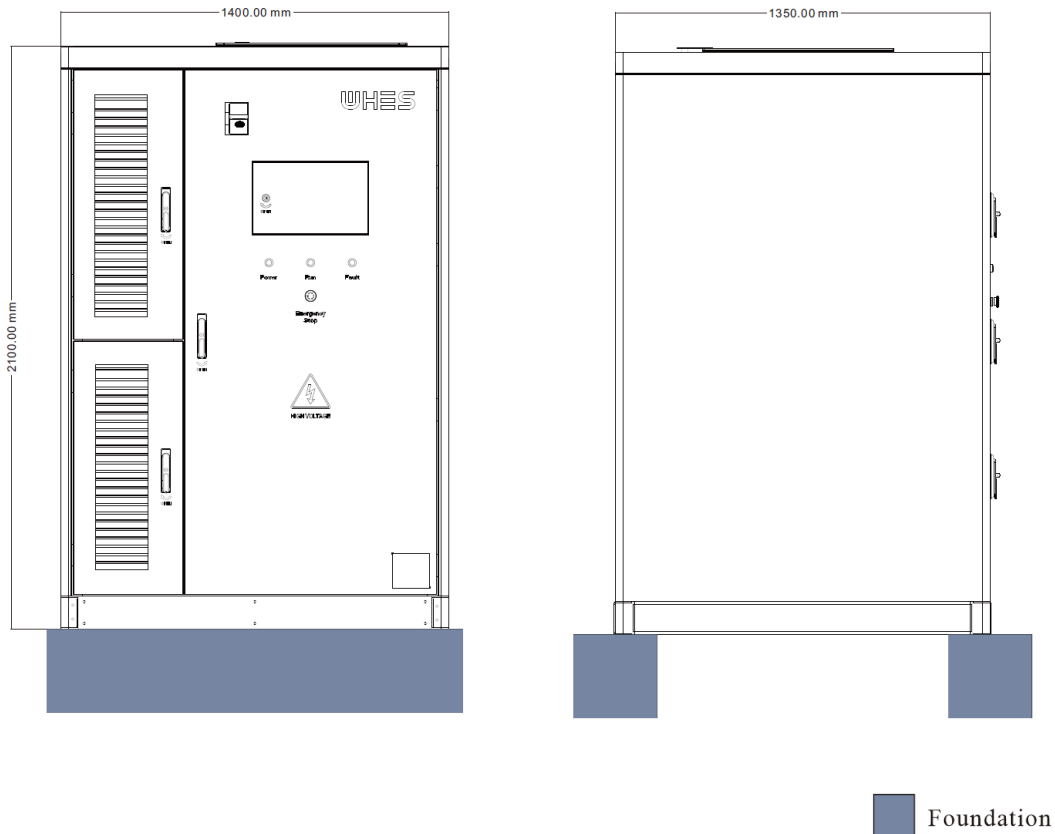

Figure 2-1 Appearance and Dimensions

NOTE

The foundation is recommended by WHES. The customers can design the construction according to the features of the product. Make sure it follows the site requirements.

2.4 Components

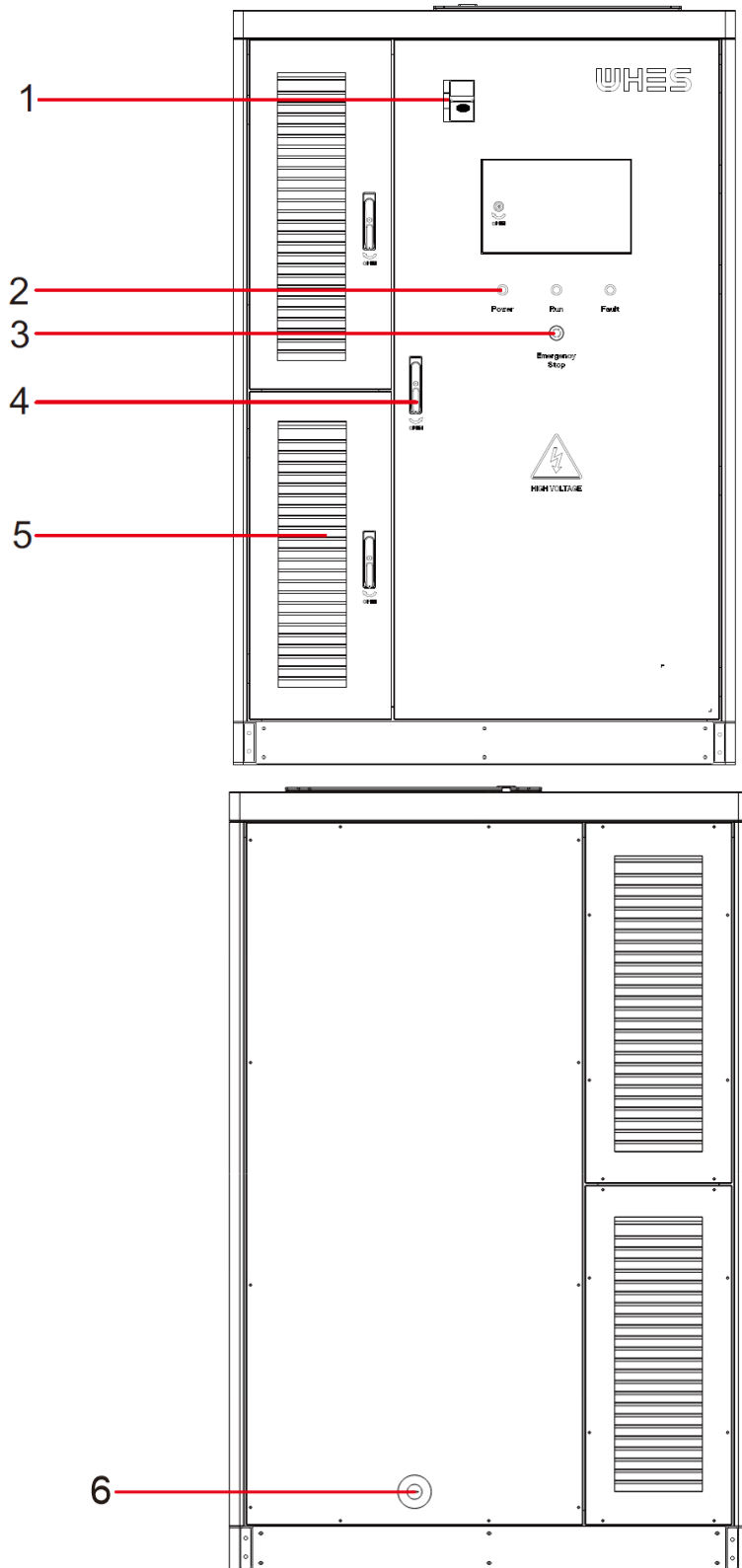

Figure 2-2 Equipment Front View

Table 2-1 Component Configuration

No.	Name	Quantity	NOTE
1	Audible and visual alarm	1	Provide audible and visual warnings for hazards to alert users in a timely manner.
2	Indicator	3	Power: White, power indicator Run: Green, run indicator Fault: Red, fault indicator
3	Emergency-stop switch	1	Press the button to stop the system in the event of an abnormal equipment condition.
4	Locking handle	1	Turn the handle to open the control cabinet door.
5	Cooling air vent	2	Ventilation for heat dissipation
6	Water fire-fighting interface	1	DN25*15 internal thread reducing pipe fitting

 BEWARE

Regarding Component 6 (Firefighting Water Interface) in Table 2-1 Component Configuration.

The equipment enclosure is supplied with a DN25 × DN15 female-threaded reducing adapter and a DN25 pipe cap.

At the project site, the customer shall install the supplied DN65 × DN25 male-threaded reducing bushing and provide a DN65 hose coupling for connection to the local firefighting water hose.

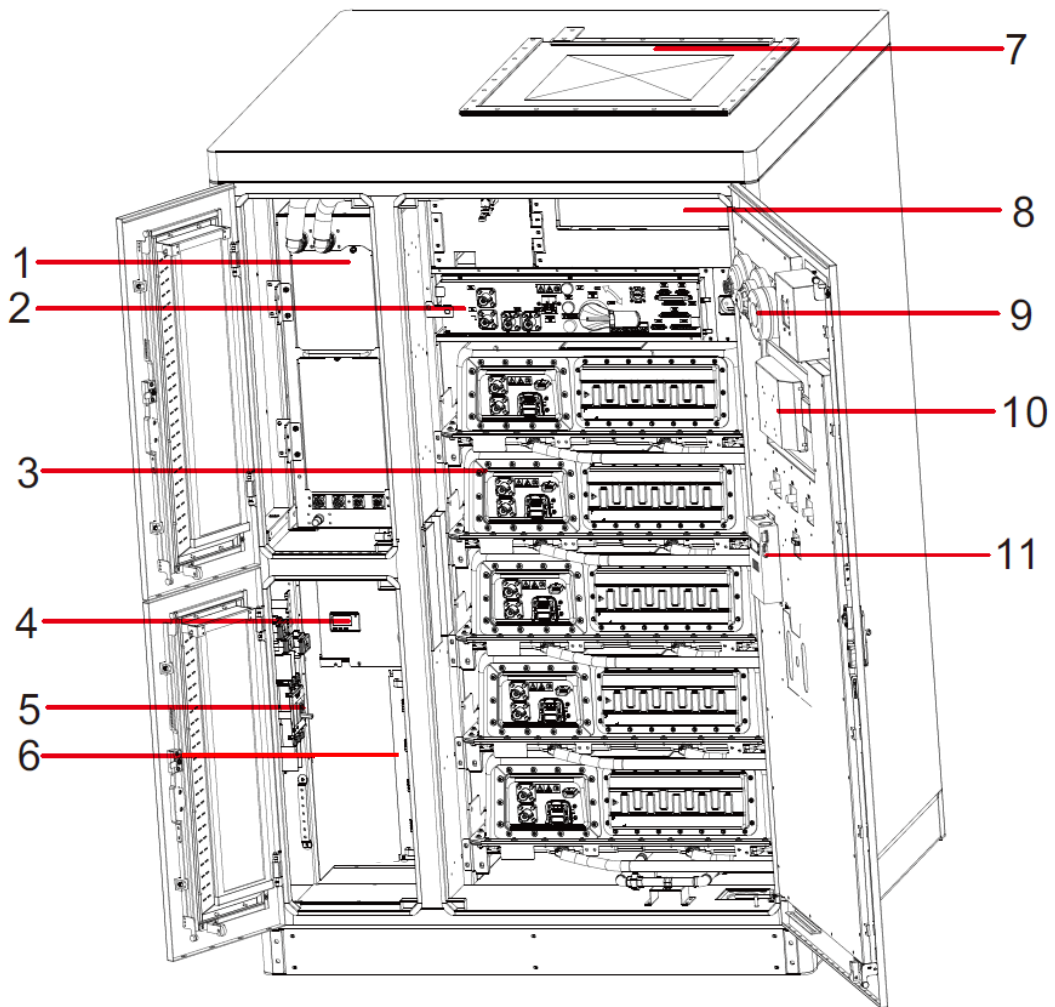

Figure 2-3 Equipment Components

Table 2-2 Component Configuration 2

No.	Module Description	Quantity	NOTE
1	Liquid Cooling Unit	1	Efficient heat dissipation to maintain stable equipment operation.
2	HV Box	1	Used for management, protection and monitoring of the battery pack.
3	Battery pack	1	Core energy storage unit, ensuring continuous power supply.
4	Meter	1	ADL400N-CT (See G Energy Meter Configuration)
5	Moulded Case Circuit Breakers	1	Grid input line connection position.
6	PCS	1	50kW power module, enabling power conversion and management to optimize the ESS performance

User Manual

7	Explosion Vent Panel	1	Directional venting to quickly release internal pressure, and ensure cabinet safety.
8	UPS	1	Provide stable auxiliary power output.
9	Aerosol	1	Aerosol fire extinguishing in seconds to suppress re-ignition without residue, and ensure cabinet safety.
10	Display screen	1	Local control panel, connected to PANGU LITE.
11	Dehumidifier	1	Reduce humidity to prevent the ESS from moisture damage.

2.4.1 Energy Storage Battery System

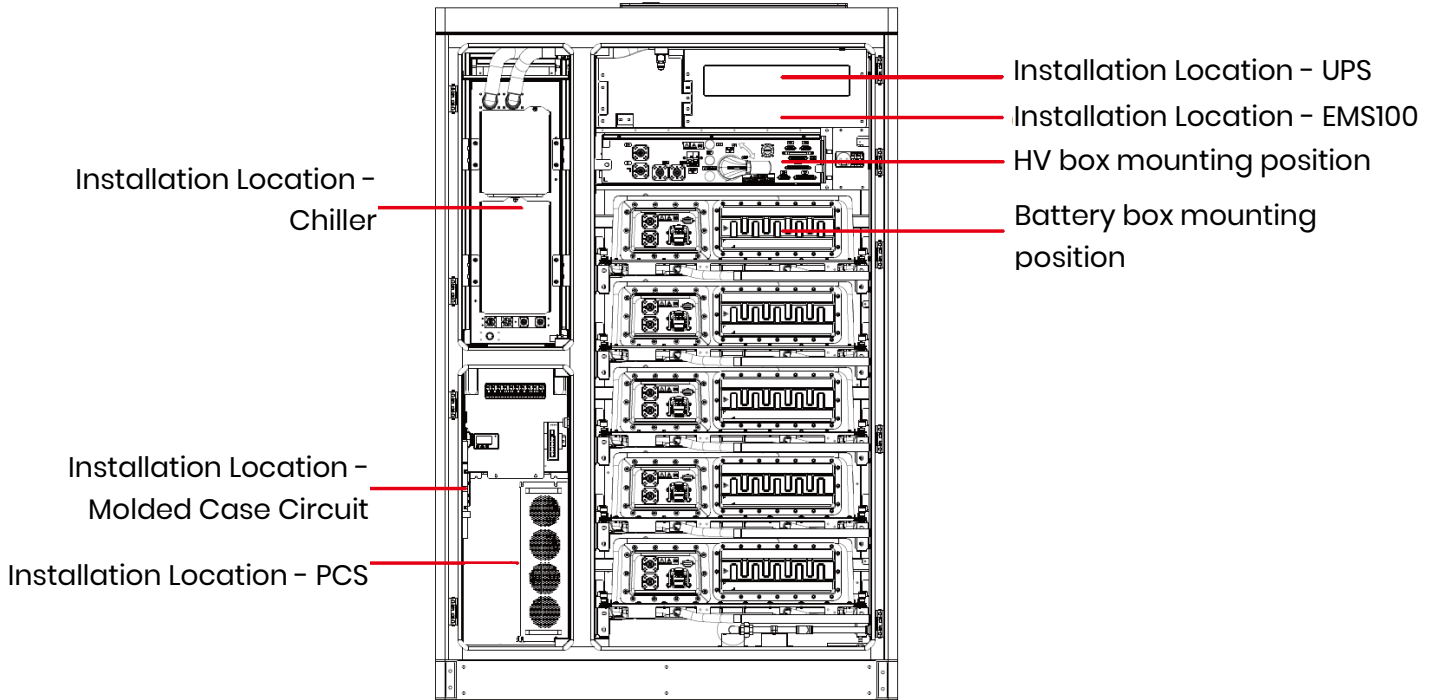

Figure 2-4 Battery System Position

2.4.1.1 EMS100

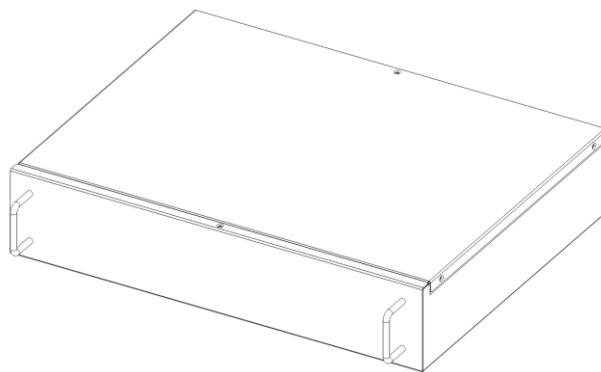

Figure 2-5 EMS100 Appearance

Module description: The EMS100 is a control host designed for energy storage battery management systems. It enables real-time data and fault information acquisition, fault protection, MCU closing control for battery packs; and provides

real-time operating data acquisition, power control, and fault protection for the PCS. It also supports interlocked control with liquid cooling and fire protection systems, and configuration of various control strategies to ensure reliable system operation.

Table 2-3 Technical Parameters

Project name	Parameter Description
CPU	ARM main control platform, Cortex A7 core
Memory	512MB DDR3
Memorizer	4GB eMMC
Operation Systems	Linux
Connection	Ethernet: 2 ports, 10/100Mbps, support Modbus TCP protocol
	RS485: 4 ports, Modbus RTU
	CAN: 2 ports
	DI: 4 ports, support passive dry and wet nodes (24V \ 9V)
	AI: 2 ports, current (4~20mA), voltage (0~5V, 0~10V), resistance (e.g., 0~10k or resistance-type temperature and humidity sensor)
	DO: 4 ports, relay output (5A@AC250V/DC30V)
Power Supply Mode	200 ~ 240Vac
Working temperature	-30 ~ 60°C
Storage temperature	-40 ~ 85°C
Operating Humidity Range	0~95% (no condensation)

2.4.1.2 HV Box

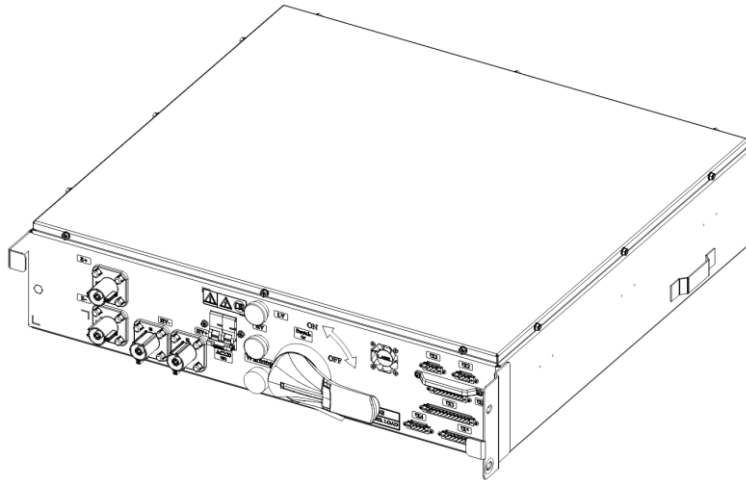

Figure 2-6 HV Box Appearance

Module description: Integrated with SBMU, DC fan, circuit breaker, fuse, 24V power supply, etc.

Main functions:

- Collects battery cluster current and total voltage;
- Provides power cut-off protection in case of abnormal battery conditions;
- Enables independent capacity and SOC calibration under BMS control, providing a benchmark for subsequent charge/discharge management;
- Collects CSC information via CCAN downwards and transmits it to MBMU via MCAN upwards.

Table 2-4 Technical Parameters

Model	HVBX-A-140-01
Application Scenario	Outdoor
Rated DC Voltage	DC1500V
Rated DC Current	140A
Auxiliary Power Supply Maximum Power	150W
Auxiliary Power Supply Rated Voltage	230V, 50Hz
Communication protocol	CAN
Dimensions (W*D*H)	664.54*749.49*221.5mm
Weight (approx.)	30kg

2.4.1.3 Battery Pack

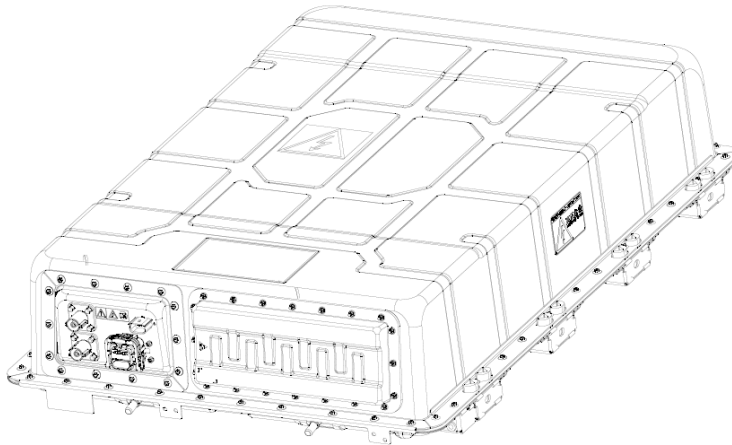

Figure 2-7 Battery Pack Appearance

Module description: The battery pack consists of 52 cells and a CSC (cell supervision circuit). Each battery is equipped with 8 NTC temperature sensors. The cell supervision circuit collects voltage, current, and temperature data from the cells inside the battery pack.

Table 2-5 Technical Parameters

No.	Item		Specification
1	Basic Parameter	Nominal Capacity (kWh)	46.59kWh
2		Cell Number	52
3		Cell Self-discharge Rate/month	≤3.5%
4		Voltage Range (V DC)	145.6~187.2
5		Nominal Voltage (V DC)	166.4VDC
6		Rated charging rate	0.5P
7		Rated discharging rate	0.5P
8		Maximum continuous current	160A 1min

User Manual

9		Equalization way	Passive equalization
10	Working Environment	Charge/Discharge Temperature (°C)	Charging: 0~55°C Discharging: -20~55°C
15	General Parameter	Dimension (W*D*H)(mm)	810mm(W)*1152mm(D)*243.4mm(H)
16		Weight (kg)	330±10kg
17		IP code	IP66
18		Cooling mode	Liquid cooling
19		Communication	CAN
20	Test & Certification	Battery module	UN38.3
21			UL9540A(V3)

2.4.2 Energy Storage Converter System

2.4.2.1 PCS

Module description:

The energy storage converter system is mainly used to achieve power conversion between the grid and the battery, and enable monitoring and management of the exchange process. The energy storage converter supports two operation modes: on-grid and off-grid.

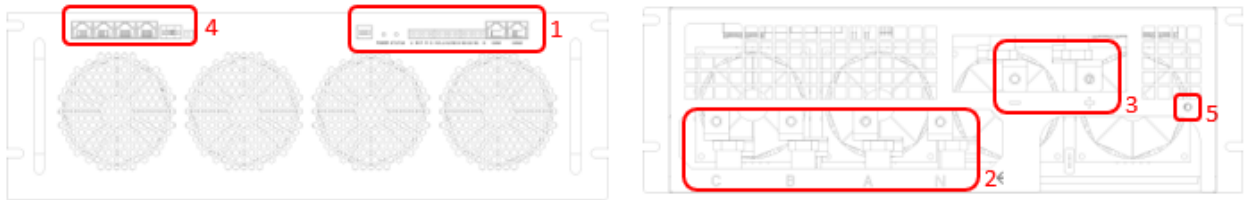

(1) Signal port (2) AC interface (3) DC interface (4) Paralleling interface (5) Grounding port

Figure 2-8 PCS Appearance

- The signal port consists of a dip switch, indicator, Phoenix terminal, and RJ45 terminal.

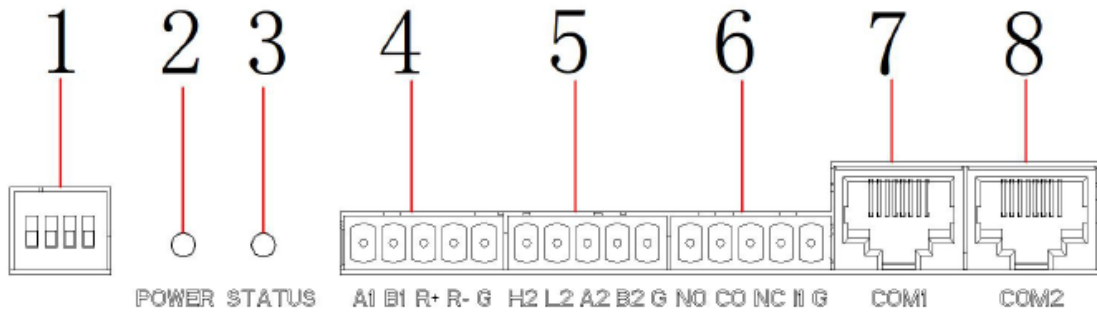

Figure 2-9 Signal Ports Schematic

Table 2-6 List of Signal Ports

No.	Name	NOTE
1	Dip Switch Address	Set different addresses to enable paralleling operation of multiple units.
2	Power Indicator (Red)	The power indicator illuminates steadily after the equipment is connected to AC/DC power supply.
3	Status Indicator (Green)	The status indicator illuminates steadily when the equipment is in operation.
4	485 Communication Interface 1	Internal communication interface
5	485 Communication Interface 2	Internal communication interface 2
6	I/O Interface	I/O Communication Interface
7	RJ45 Interface 1 (CAN Communication Interface)	Equipment external communication port
8	RJ45 Interface 2 (CAN Communication Interface)	Equipment external communication port 2

● The AC interface is connected to the grid using a copper busbar secured with M6 screws. The terminals are arranged as follows: L1, L2, L3, and N, from left to right.

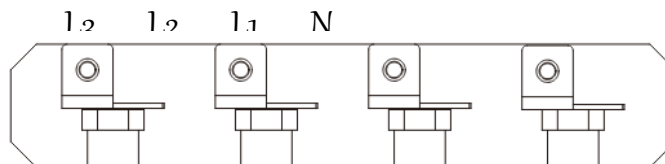

Figure 2-10 AC Interface Schematic

● The DC interface is connected to the DC power source using a copper busbar secured with M6 screws. The terminals are arranged as follows: DC- and DC+, from left to right.

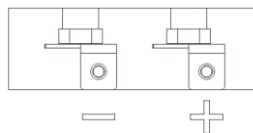

Figure 2-11 DC Interface Schematic

● Paralleling interface: For paralleling operation of multiple modules, it is required to connect their paralleling interfaces with a paralleling cable.

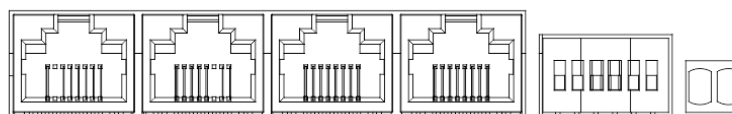

Figure 2-12 Paralleling Interface Schematic

Table 2-7 Technical Specifications of 50kW Air-Cooled Energy Storage Converter

Model	WH-BEC-50AC
Rated power	50kW
DC operating voltage range	500V~950V
DC-side full-load voltage range	600V~950V
Max. DC current	110A
Rated AC voltage	400Vac, 3W+PE
Rated frequency	50Hz(±5Hz)
Rated alternating current	72A
Current distortion	< 3% (rated power)
Power factor adjusting range	-1 lead to +1 lag
Applicable batteries	Lithium battery
Charging method	As directed by BMS/three-gradation charge
Operation mode	Constant current, constant power, AC voltage source
Max. efficiency	97.8%
Size (W×D×H)	483 (444 when the mounting lug is excluded) *600*150 mm
Weight (approximate value)	35kg
Inverter Topology	Non-isolated
Ingress protection	IP21
Operating temperature	-25°C to +55°C (derating when the temperature is greater than 45°C)
Relative humidity	0 to 95% (without condensation)
Cooling method	Smart air cooling
Noise	<70dB
Altitude	3000 m (derating when the altitude is higher than 2000 m)
Overvoltage category(OVC)	II for DC side ,III for AC side
Communication interface	CAN

- **GND port is Used to connect the equipment to the earth.**

2.4.3 Liquid Cooling System

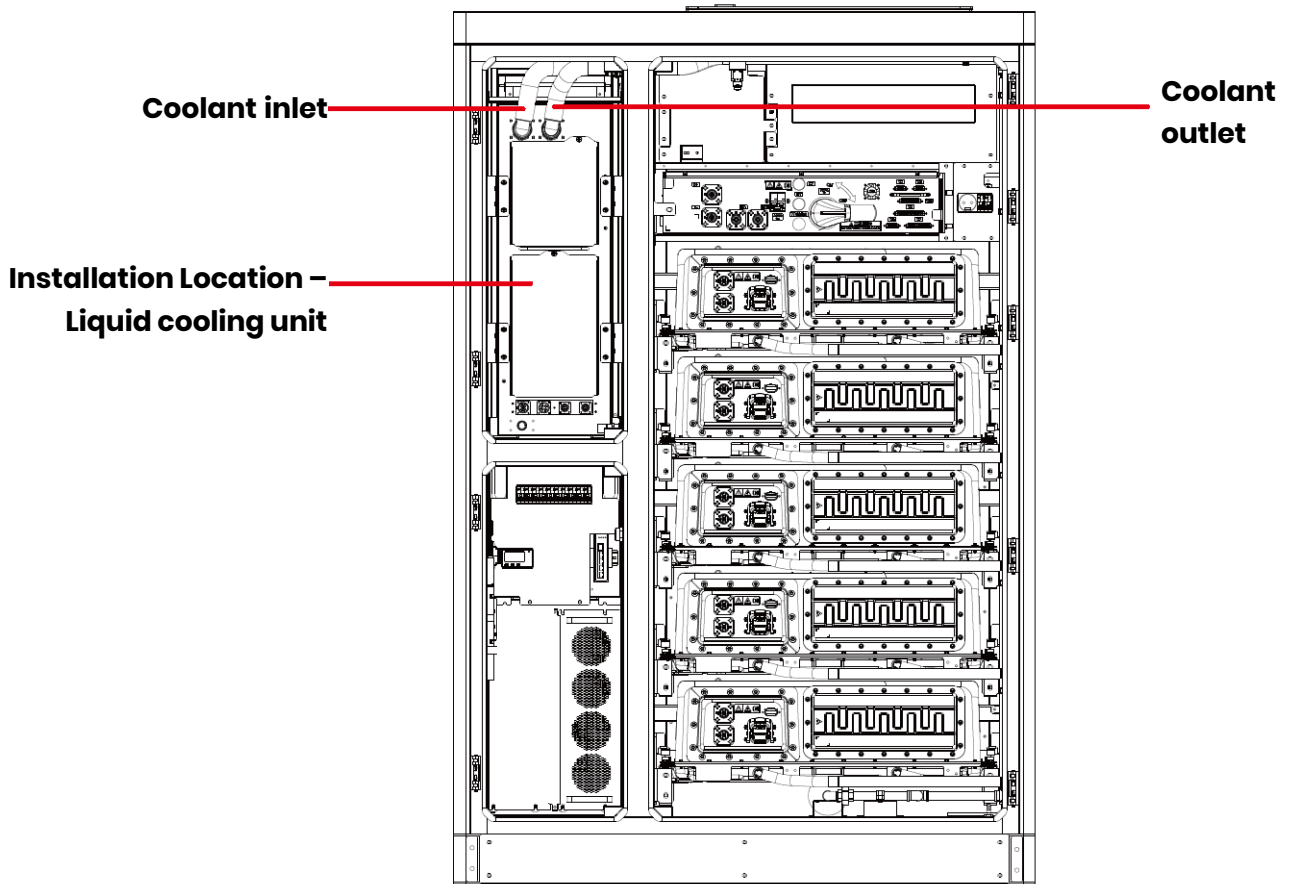

Figure 2-13 Liquid Cooling System Position

2.4.3.1 Liquid Cooling Unit

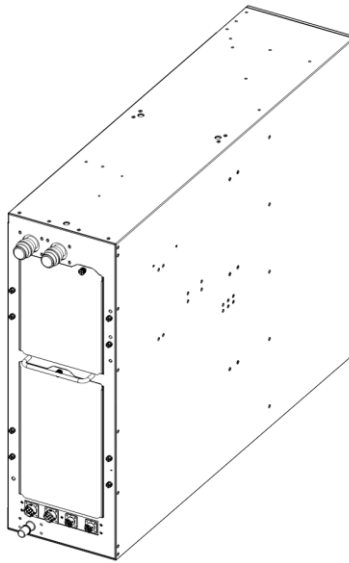

Figure 2-14 Liquid Cooler Appearance

Component description: The liquid cooling unit adopts an integrated structure, with all components packaged in a single chassis for easy installation. Its modular design and compact structure facilitate embedded installation within customer frames, optimizing space utilization. The liquid cooling unit regulates the temperature of the battery pack within the ESS, ensuring it operates within an appropriate temperature range to maintain optimal system performance.

Main functions:

I. Intelligent Cooling

The chiller monitors the outlet liquid temperature in real time and achieves intelligent regulation based on the target temperature setting, ensuring that the battery operating temperature in the container remains stable within an appropriate range.

- When the outlet liquid temperature exceeds the cooling set point and activation conditions are met, the air-cooled chiller activates the cooling mode, selecting different capacities based on the actual temperature.
- To conserve energy, the air-cooled chiller shuts down the compressor and reduces the circulating pump speed when the outlet liquid temperature falls below the cooling set point.

II. Electric Heating

In a low temperature environment, when the battery within the container is not being charged/discharged, the coolant temperature drops to a low level. Once the outlet liquid temperature falls below the heating set point and activation conditions are met, the chiller activates the heating mode to maintain the battery temperature within an appropriate range.

III. Remote Monitoring

The chiller communicates with the host computer via an RS485/CAN interface using the Modbus/CAN protocol. The host computer enables remote on/off operations, queries the operating status of chiller components, and sets control parameters through message interaction.

IV. Refilling Operation Instructions

Connect the chiller to the refilling tool, where the refilling pump automatically pumps the pre-stored coolant from the water tank into the circulating system to enable rapid refilling. (Refer to the section WH Refilling Process Description)

Table 2-8 Technical Parameters of Liquid Cooling Unit

Especificaciones	Value
Operating Voltage Range	200~240VAC±10%, 50/60Hz (Dual live wire input 110VAC, 60Hz)
Operating Temperature Range	-30°C ~ +55°C
Operating Relative Humidity Range	5% ~ 95%
Storage Temperature Range	-40°C ~ +70°C
Storage Relative Humidity Range	5% ~ 95%
Transport Method	Maritime transportation, road transportation
Operating Altitude	0m~4000m Performance decreases by 3% per 1,000 m altitude gain between 1,000 m and 4,000 m.
Overall dimensions (W*D*H)	275mm×1185mm×1074mm

2.4.4 Environmental Control System

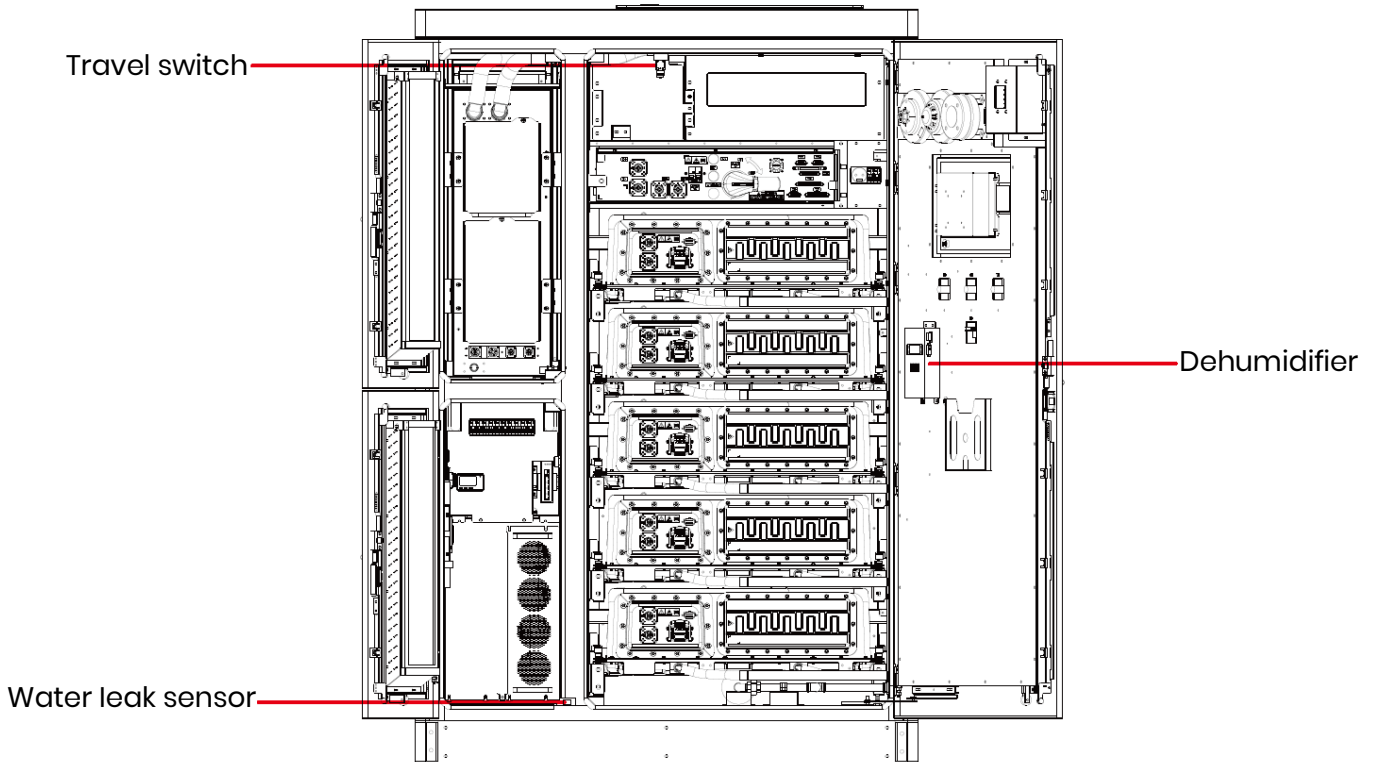

Figure 2-15 Environmental Control System Position – Front View

2.4.4.1 Travel Switch

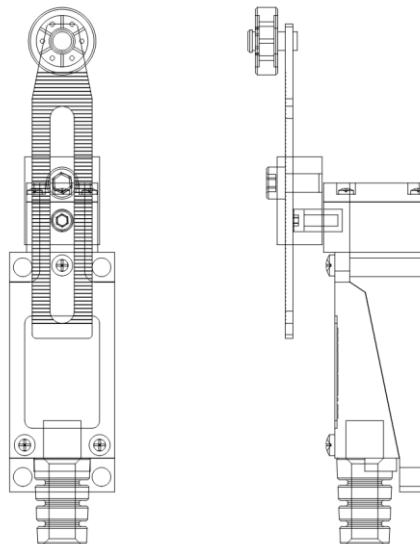

Figure 2-16 Travel Switch Appearance

Component description: The access control switch of the energy storage system functions when the door is opened to a specific position, alerting that the door is not closed, preventing erroneous operation of the system, and ensuring its safe operation.

Table 2-9 Technical Parameters

Model	CHNT/YBLX-ME/8108
Protection grade	IP62
Operation Frequency	20 cycles/min
Ambient temperature	-5°C~+40°C
Relative humidity	When the maximum temperature is +40°C, the relative humidity of the air shall not exceed 50%. Higher relative humidity is allowed at lower temperatures, e.g., 90% @ 20°C. Special measures should be taken for occasional condensation due to temperature variations.
Rated Voltage	AC-15:380V DC-13:230V
Rated Operating Current	AC-15:0.8A DC-13:0.16A
Installation Category	II
Pollution Level	Level 3
Rated Insulation Voltage	415V
Rated Impulse Withstand Voltage	2.5kV
Altitude	≤2000m
Installation Conditions	To be installed in a place without significant shaking, impact or vibration

2.4.4.2 Water leak sensor

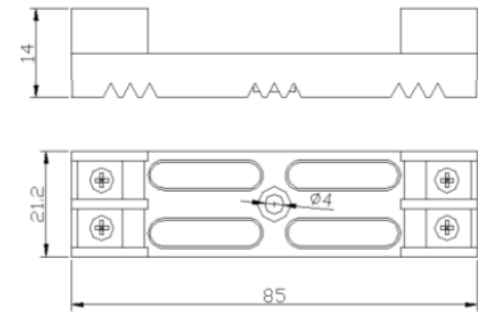

Figure 2-17 Water leak sensor appearance

Component description: This sensor needs to be used with a transmitter (see 2.4.4.3). When the two poles of the sensor come into contact with water, the impedance changes. Based on this working principle, the sensor utilizes a dedicated integrated chip to amplify, shape, and compare the water immersion input signal, and output a dry contact or high/low level change signal to indicate the presence of water at the transmitter location.

Table 2-10 Technical Parameters

Sensor model	JS-DP Series
Working temperature	-20°C~60°C
Operating Humidity	0%RH ~95%RH
Product Weight	40g

2.4.4.3 Dehumidifier

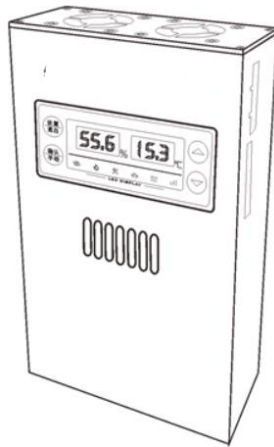

Figure 2-18 Dehumidifier Appearance

Component Description: The dehumidifier has the following features: compact, lightweight, easy and quick to install; switchable automatic and manual dehumidification modes, adjustable temperature and dehumidification activation values; active condensation of dehumidification air duct, heated dehumidification of exhaust gas, effectively achieving comprehensive control of moisture prevention and dehumidification in the closed space of electrical cabinets.

Table 2-11 Technical Parameters

Model		JY-760A	
Power Supply	AC230V	Dehumidification Efficiency	380 mL±5%/24 h (@60W 35 °C RH=85%)
Heating Power	50 ~ 300W	Dehumidification Temperature	5°C ~ 45°C
Power Selection	20W~60W	Working temperature	-25°C ~ 75°C
Humidity Detection Range	20%RH~98%RH	Temperature Detection Range	-20°C ~ 85°C
Dehumidification Activation Value	25%RH~98%RH	Temperature Activation Value	1°C ~ 55°C
Humidity Measurement Accuracy	±3%RH	Temperature Measurement Accuracy	±1°C
Display Mode	6-digit	Display Resolution	0.1
Shell Material	Aluminum Alloy	External Dimensions	180×62×110mm (W*D*H)
Net weight	1kg	Drainage Pipe	Silicone D10mm

2.4.5 Fire Protection System

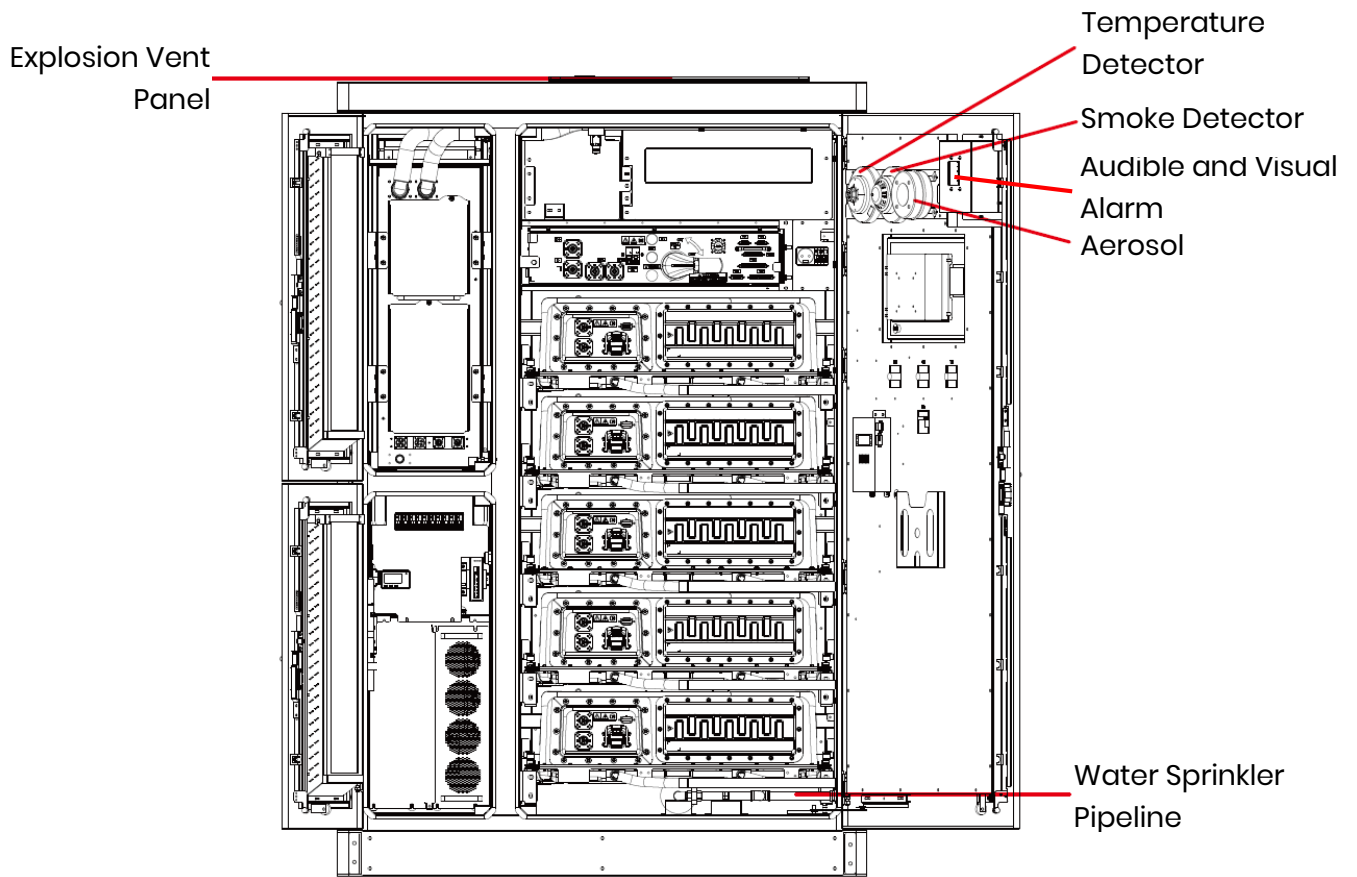
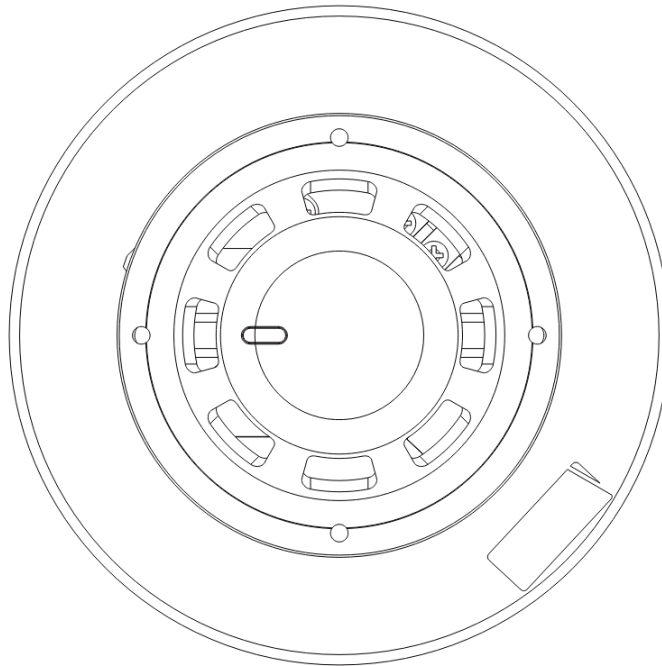
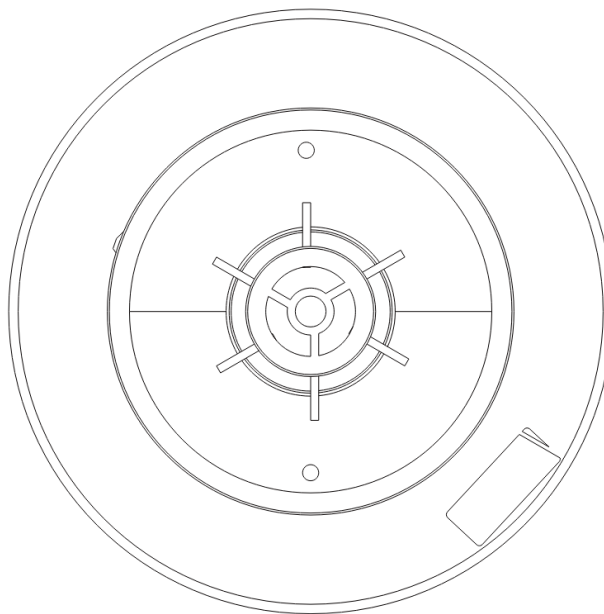

Figure 2-19 Fire Protection System - Front View

2.4.5.1 Smoke and Temperature Detectors



■ **Figure 2-20 Smoke Detector Appearance**



■ **Figure 2-21 Temperature Detector Appearance**

Component Description: The device is a reliable, high quality photoelectric smoke detector. It can be used in all open photoelectric fields, where fires with high heat output are prone, including in-pipeline applications. Ideal for detecting smoldering and fast-burning flame fires, or where environmental conditions do not permit the use of other detection methods.

Table 2-12 Technical Parameters

	Product model	DCD-135/-190 (Temperature detector)
1	Trigger temperature	135°F±7.5°F 190°F±7.5°F
2	Supply voltage	15.0-33.0VDC (two-wire)
3	Working current	40μA (24VDC)
4	Impulse current	160μA (24VDC)
5	Alarm current	150μA (24VDC)
6	Ambient temperature	32° ~ 120°F
7	Contact capacity	150μA (24 VDC)
8	Shell material	PC/ABS mixture

	Product model	SOC-24V (Smoke detector)
1	illuminant	Infrared emitting diode
2	Supply voltage	12 or 24 VDC
3	Operating voltage	8 - 35.0 VDC
4	Maximum voltage	42v VDC
5	Impulse current	160μA (24VDC)
6	Alarm current	150μA (24VDC)
7	Wind speed range	0-4000fpm
8	Maximum humidity	95%RH
9	Ambient temperature	32°F ~ 120°F
10	Shell material	PC/ABS mixture

2.4.5.2 Audible and Visual Alarm

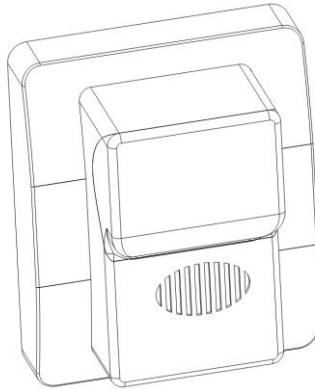

■ **Figure 2-22 Audible and Visual Alarm – Appearance**

Component Description: This audible and visual alarm can provide audible and visual alerts when triggered. It can be used with a bus-type fire alarm controller via the output module. When the fire alarm controller issues a start command, the output module activates the audible and visual alarm accordingly. Then, the audible and visual alarms emit intense visual alerts and piercing audible signals to notify on-site personnel of the fire occurrence and the necessity to implement evacuation measures, thereby preventing the fire incident from escalating.

2.4.5.3 Aerosol

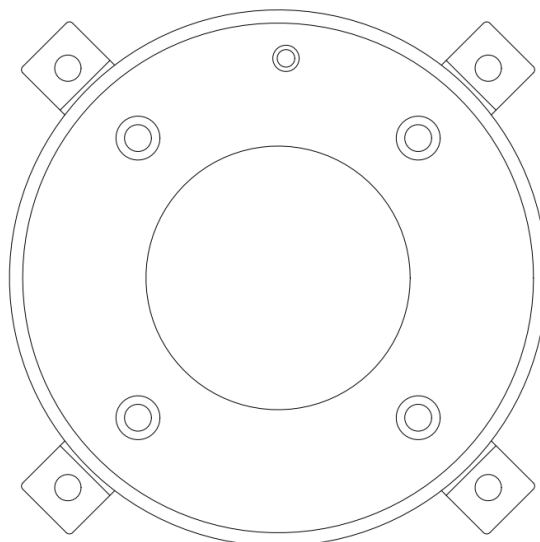

■ **Figure 2-23 Aerosol Appearance**

Component Description: The DSPA aerosol generator is a high-efficiency fixed fire extinguishing component, featuring a non-pressure design that allows for direct installation in the confined space to be protected. After activation, the device releases a fully flooded aerosol cloud that quickly spreads to cover the entire protected area, and effectively extinguishes Class A (solid), Class B (liquid), and Class C (gas) fires through

the dual effects of chemical suppression and suffocation.

Table 2-14 Technical Parameters

Parameters	Value
Model	11-2
Part Number	DSPA-ART00012
Dimensions	124×34 mm
Total Weight	800 g
Compound Weight	170 g
Volume Coverage	1.3~3.9 m ³
Discharge Time	12 sec
Activation Current	Built-in starter, 1.3A
Operation Conditions	-40°C~75°C, max. 95% humidity (at 54°C)
Colour	RAL 3000 (standard), other colors are available for customization

2.4.5.4 Explosion Vent Panel

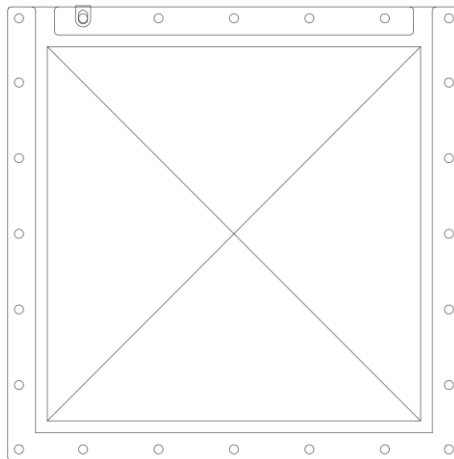

Figure 2-24 Explosion Vent Panel – Appearance

Component Description: The explosion vent panel plate is an important safety component of the energy storage cabinet. It is designed to release high-pressure gas and smoke in a controlled manner, preventing the cabinet from exploding in the event of a sudden rise in internal pressure due to battery abnormalities such as thermal runaway or short circuit. The explosion vent panel is installed on the top of the enclosure and is linked with the smoke and temperature detection and fire extinguishing system, creating a multi-layer protection strategy as the last line of defense. It is also used to minimize secondary hazards through directional pressure venting channels, ensuring the safety of both equipment and personnel.

2.5. Working Principle

2.5.1 Circuit Diagram

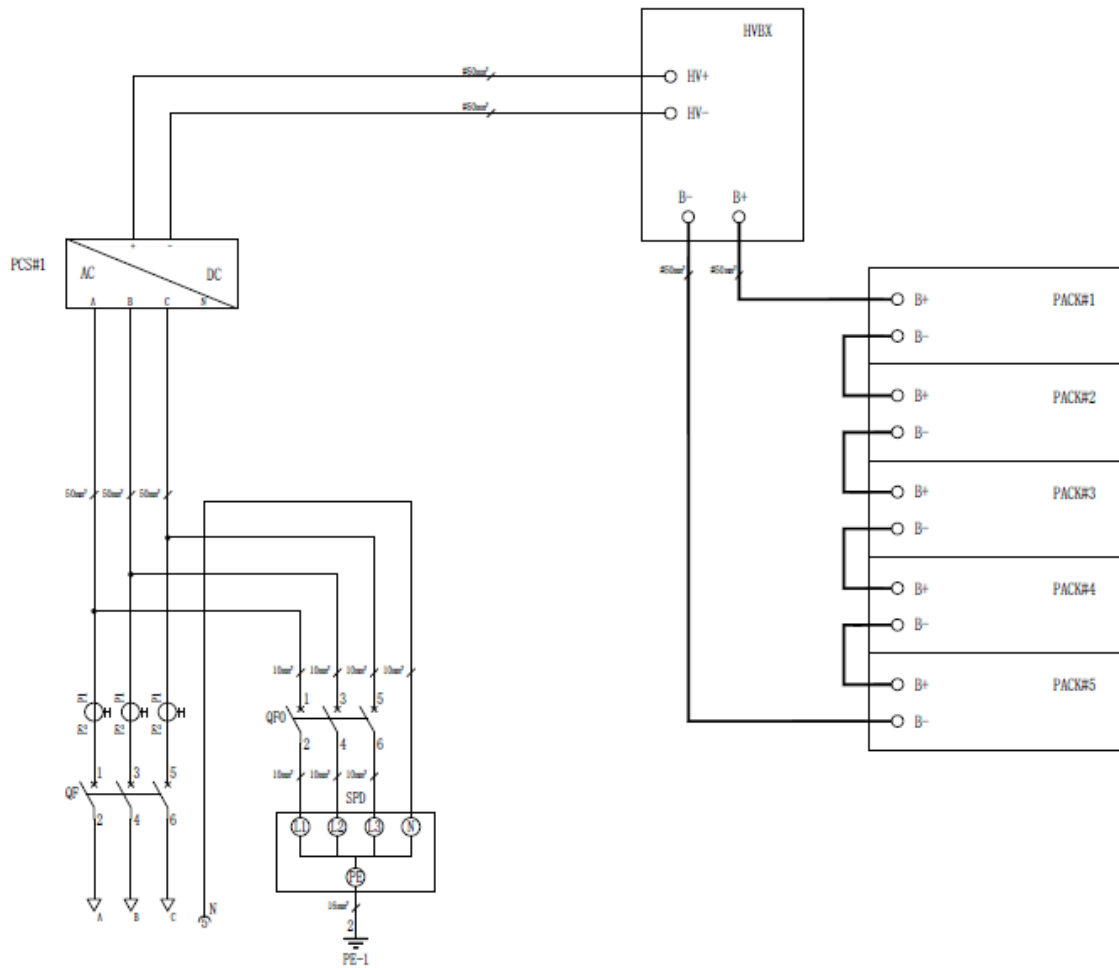

Figure 2-27 Circuit Diagram

2.5.2 Fire Protection Logic Diagram

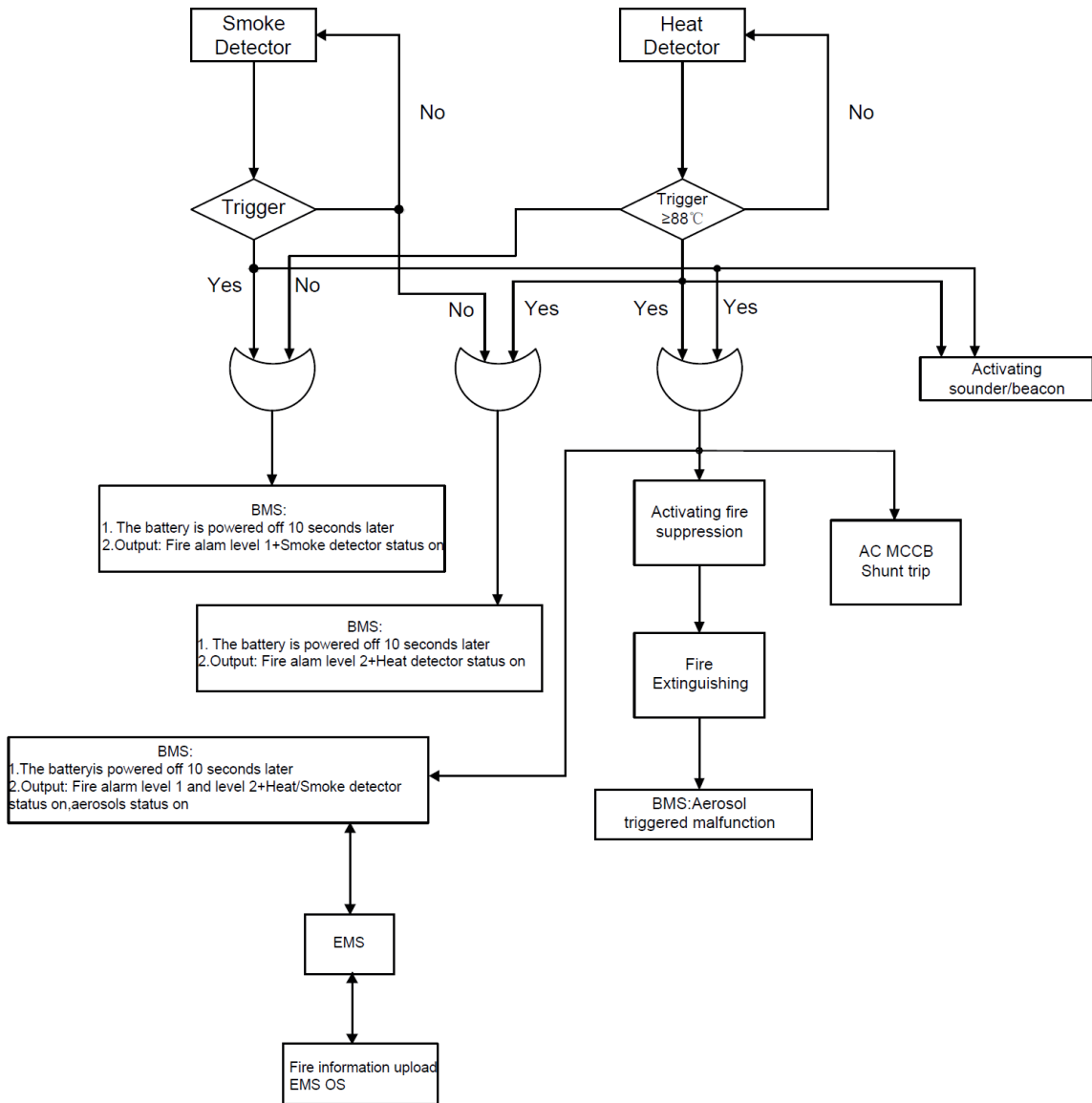

Figure 2-28 Fire Protection Logic Diagram

2.5.3 Equipment Status

The ESS has 5 operating conditions: active, inactive, fault, standby, and offline.

Table 2-16 Equipment Status

Equipment Status	NOTE
Standby	The all-in-one ESS is powered on and connected to the grid, ready for operation at any time. However, major operations such as charging and discharging are not currently being performed.
Charge / Discharge	The all-in-one ESS is powered on and connected to the grid, with all components functioning properly to perform charging and discharging operations, ensuring stable power supply for the system.
Shutdown	The all-in-one ESS is inactive, with the relay switch disconnected and no charging or discharging activities taking place. It is currently in non-operational mode.
Breakdowns	The all-in-one ESS has detected an internal error, triggering a fault alarm that must be addressed before it can operate.
Offline	The all-in-one ESS is disconnected from the monitoring system, and no data interaction or remote control is possible.

2.5.4 Demand response mode (DRM)

Connection:

Directly connect to the inverter communication port via DRM. You might need a 2-core twisted-pair cable.

The front of TIANWU reserves DRM0 interfaces (XT0-5& XT0-6, always open). When the dry contact closes normally, the system shuts down and reports an emergency stop fault to the outside of the cabinet

Table 2-19 DRM0 Terminal schematic table

XT0	
XT0-3	The DRM0 function can be achieved by connecting XT0-3 and XT0-4
XT0-4	

2.6 Compatible Grid Types

The ESS is compatible with the following grid types: TN-S, TN-C, TN-C-S, TT, and IT.



For TN-S, TN-C, TN-C-S, and TT systems, the neutral (N) line of the ESS must be connected to the grid.

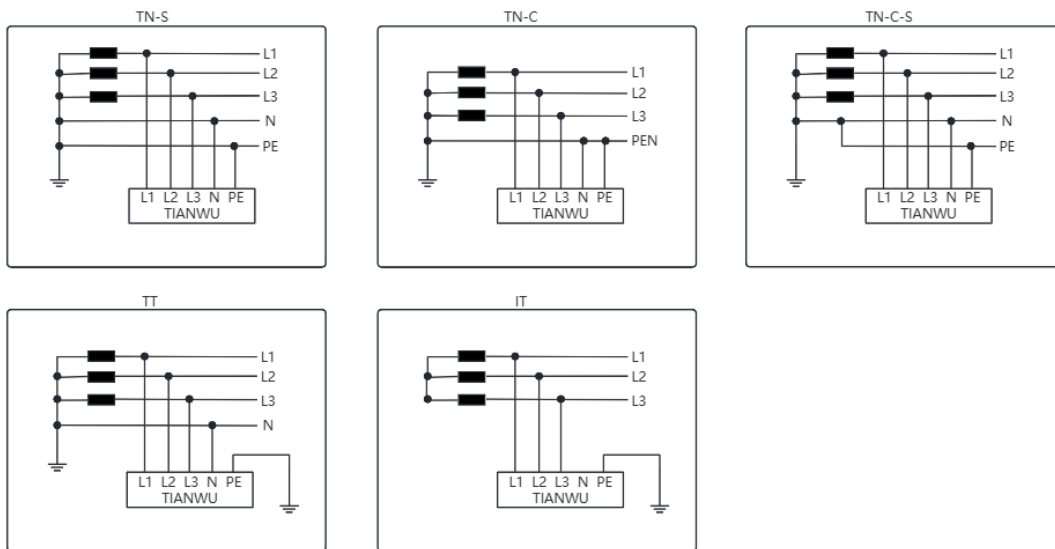

Figure 2-26 Compatible Grid Types

2.7 Application Scenarios

In a system where PVs, ESS, and the grid operate in tandem, interconnected devices form a dynamic energy loop through intelligent scheduling. During the day, PV inverters convert solar energy into AC power, prioritizing the power supply for real-time loads. Any surplus electricity is automatically directed to the all-in-one ESS for storage. When sunlight diminishes or load demand surges, the ESS instantly switches to discharge mode, supplementing power gaps according to the preset strategy (e.g., during peak electricity pricing periods). Meanwhile, the EMS continuously compares grid electricity prices with energy storage costs in real time, enabling the ESS to efficiently draw power in reverse from the grid during off-peak periods. The grid serves as a stable backup, working with the ESS to provide dual assurance for power supply under extreme weather conditions while facilitating metering and trading of surplus electricity fed back into the grid via bidirectional meters. This entire process is automatically optimized through predictive algorithms and real-time monitoring, achieving a triple balance: maximizing clean energy utilization, minimizing electricity costs, and ensuring power supply reliability.

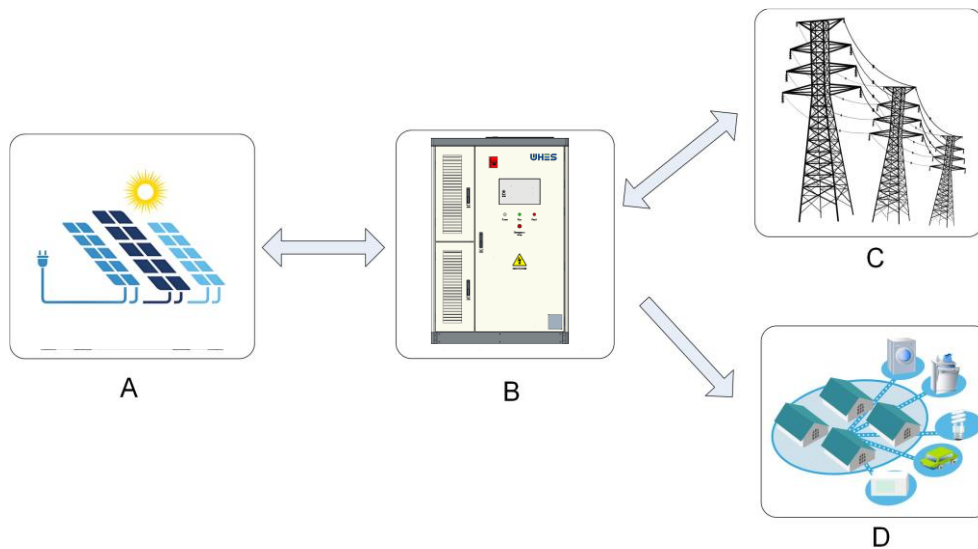

Figure 2-29 AC Coupling Application Diagram

Table 2-17 Description of Application Diagram

Identification	Equipment	Description
A	PV Inverter	Convert the DC power generated by PV cells into AC power.
B	Energy storage integrated machine	Integrate energy storage and power conversion for flexible energy management.
C	Grid	/
D	Load	/

3 Site Requirements

3.1 Site Selection Requirements

 **BEWARE**

The site shall be selected in accordance with GB 51048: Design Code for Electrochemical Energy Storage Power Station, NFPA 855: Standard for the Installation of Stationary Energy Storage Systems, and applicable local regulations.

The ESS is designed for outdoor installation. For indoor application, refer to local regulations. General site selection requirements:

- Select the installation site at a high elevation above the maximum historical water level rather than in a low-lying area.
- Maintain a minimum distance of 2 km from airports, landfills, riverbanks, and dams.
- Choose a spacious location and ensure a 10m unobstructed area around the site.
- Maintain a minimum distance of 50 m from residential areas to avoid noise pollution.
- Ensure convenient access to transportation facilities and reliable fire suppression systems.
- Provide sufficient space for current and future needs, including potential expansion throughout the life cycle.
- Choose a well-ventilated location.
- Avoid installing the ESS outdoors in saline areas where the ESS is prone to corrosion and subsequent potential fires. Saline areas refer to areas within 2 km of the coastline or affected by sea winds. Areas affected by sea winds vary based on meteorological conditions (e.g., typhoons, seasonal winds) and terrain features (e.g., dikes, hills).

 **NOTE**

1. If the selected site fails to meet national standards for safety clearance, it is recommended to select a new site.
2. If no suitable alternative site is available, it is recommended to install a fire wall with a minimum 3 h fire resistance rating for safety, with adequate space for equipment transport, installation and maintenance.
3. According to T/CEC 373-2020, the length and height of the firewall shall extend 1m beyond the outer perimeter of the prefabricated cabin. According to NFPA855-2020: Standard for the Installation of Stationary Energy Storage Systems, an independent fire wall with a 1 h fire resistance rating allows the spacing to be reduced to 914 mm.

Site selection shall exclude locations, areas, and places that are not recommended by industry standards and regulations, including but not limited to:

- Areas with high vibration, noise, or electromagnetic interference;
- Places where dust, fumes, harmful or corrosive gases are produced or are present;
- Places where corrosive, flammable, or explosive materials are produced or stored;
- Places with existing underground facilities;
- Areas with poor geological conditions, such as rubber soil, soft soil layers, or areas prone to water accumulation and subsidence;
- Earthquake faults and areas with seismic intensity greater than 9 degrees;
- Locations susceptible to direct hazards such as mudslides, landslides, quicksand, or caves;
- Locations affected by mining subsidence (dislocation) hazards;
- Areas affected by explosion hazards;
- Areas at risk of flooding due to dam or dike failure;
- Important water source and sanitary protection zones;
- Historical and cultural relic protection zones;
- Crowded areas, high-rise buildings, and underground structures.

3.2 Forklift Requirements

- Before using the forklift, ensure that the forklift meets the load-bearing requirements: The load-bearing capacity must be at least 5 tons.
- The recommended fork length l is at least 1500 mm.
- The recommended fork width b is at least 120 mm, but not more than 180mm.
- The recommended fork thickness a is at least 60 mm, but not more than 80mm.

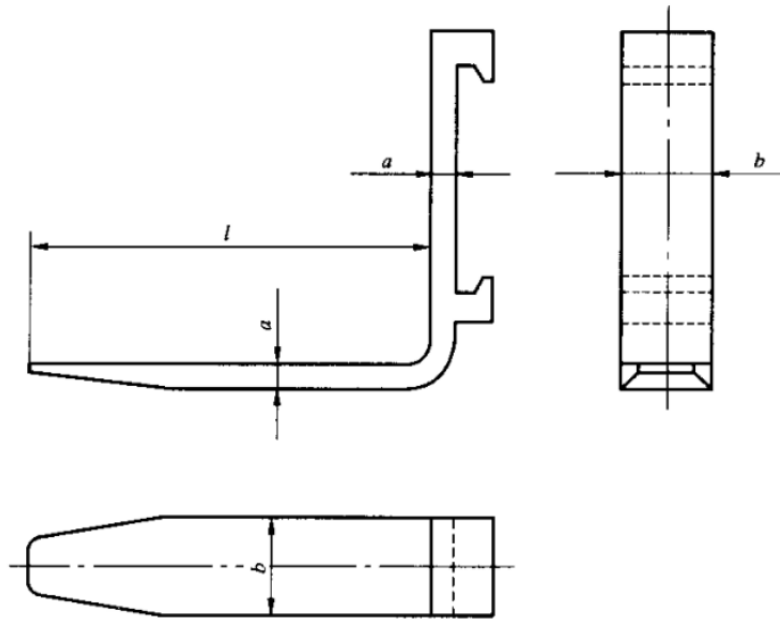

■ Figure 3-1 Requirements for forklifts

3.3 Lifting Requirements

- Before lifting, ensure that the crane and lifting rope meet the load capacity requirements. This ESS must be lifted using a lifting frame.
- When installing and disassembling the lifting equipment, avoid dragging it across the enclosure to prevent scratches.

Lifting Procedure	Precautions
<p>Before Lifting</p>	<p>Crane lifting capacity: > 3t, working radius: ≥ 2 m. If the site work conditions do not meet the requirements, seek professional evaluation.</p>
	<p>All personnel involved in lifting operations must undergo appropriate training and be qualified before performing any lifting tasks.</p>
	<p>Lifting tools must be thoroughly inspected and deemed complete before use.</p>
	<p>Ensure all lifting tools are securely attached to load-bearing fixtures or walls.</p>
	<p>Proceed only in clear, windless weather when lifting the equipment outdoors.</p>
	<p>Verify that the crane and wire rope meet all necessary specifications before lifting.</p>
	<p>Verify that all equipment doors are closed and securely locked.</p>
	<p>Ensure that the wire rope connection is secure and reliable.</p>
	<p>It is recommended to use a consistent left-to-right or right-to-left sequence to ensure smooth lifting.</p>
<p>During Lifting</p>	<p>Restrict access to the lifting area to authorized personnel only. Never stand under the crane boom.</p>
	<p>Ensure the crane is properly positioned. Avoid lifting excessive distances.</p>
	<p>Maintain stability throughout the lifting process, with no more than a 5° diagonal tilt of the enclosure.</p>
	<p>Keep the angle between the two lifting cables no more than 90°.</p>
	<p>Handle with care when lifting or lowering the equipment. Lower the enclosure slowly and smoothly to avoid impact damage to internal components.</p>
	<p>Once the container touches the base, wait until the base is evenly loaded before releasing the lifting wire ropes.</p>
	<p>Avoid dragging steel cables or spreaders with bare hands. After securing the first cabinet, proceed with lifting subsequent cabinets.</p>

4 Equipment Installation



4.1 Pre-Installation Preparation







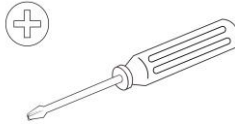
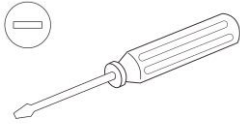



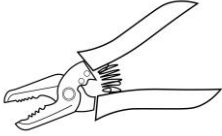
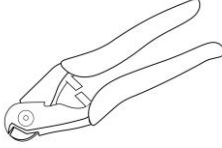

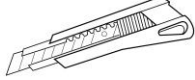
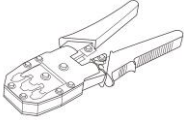
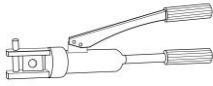
4.1.1 Tool Preparation

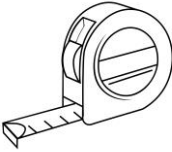

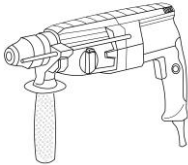

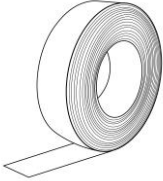
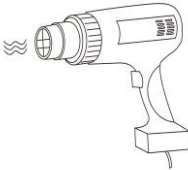
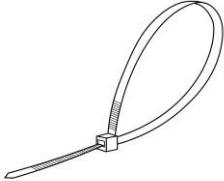
- The illustrated tools are for reference only and may differ from actual tools.
- Due to varying site conditions, this tool list may not be exhaustive. On-site installers and users are responsible for preparing unlisted tools based on actual needs.

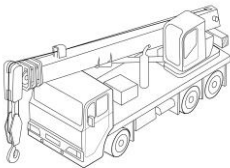
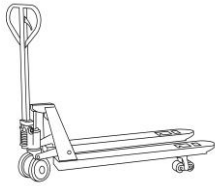



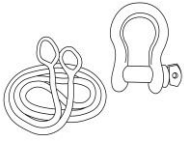

Installation Tools

 <p>Phillips Insulated Torque Screwdriver</p>	 <p>Flathead Insulated Torque Screwdriver</p>	 <p>Diagonal Pliers</p>
---	---	--

 <p>Wire Strippers</p>	 <p>Wire Cutters</p>	 <p>Rubber Hammer</p>	 <p>Utility Knife</p>
 <p>Crimping Tool</p>	 <p>Hydraulic Pliers</p>	 <p>Hex Wrench: 5mm~12mm</p>	 <p>Multimeter DC Voltage range ≥1500V DC</p>
 <p>Steel Tape</p>	 <p>Spirit Level</p>	 <p>Vacuum Cleaner</p>	 <p>Impact Drill</p>
 <p>Impact Drill Bit Φ16mm</p>	 <p>Heat Shrink Tubing</p>	 <p>Heat gun</p>	 <p>Cable Tie</p>
 <p>Insulated Ladder</p>	 <p>Crane</p>	 <p>Manual Forklift</p>	 <p>Forklift</p>

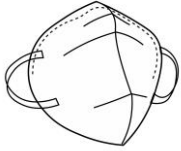
 <p>Lifting Rope & Shackle Rope length: $\geq 2200\text{mm} \times 4$</p>	 <p>Crowbar</p>
--	---

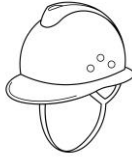
Personal Protective Equipment

 <p>Insulating Gloves</p>	 <p>Protective Gloves</p>	 <p>Goggles</p>	 <p>Dust Mask</p>
 <p>Insulating Shoes</p>	 <p>Reflective Vest</p>	 <p>Safety Helmet</p>	 <p>Seat Belts</p>

4.1.2 Pre-Installation Inspection

Outer Packaging Inspection

Before unpacking the equipment, inspect the outer packaging for visible damage such as holes, cracks, or other signs of possible internal damage, and verify that the product model is correct. If the packaging appears abnormal or the equipment mode does not match, do not open the packaging and contact your dealer immediately.



It is recommended to remove the outer packaging within 24h before preparing to install the cabinet.



If the cabinet height exceeds 2 m, ensure appropriate safety precautions for elevated work are in place when removing the outer packaging.

Deliverable Inspection

After unpacking the equipment, inspect all deliverables to ensure they are complete and free of visible damage. If any items are missing or damaged, contact your dealer immediately.

4.2 Cable Selection

For crimping OT/DT terminals, please refer to [Section A “Crimping OT/DT Terminal”](#).

Name	Type	Conductor Cross-Sectional Area	NOTE
AC Input Line	3-core outdoor copper wire	$\geq 35\text{mm}^2$ (single-core)	The cable cross-sectional areas listed in the table are the minimum required for normal system operation. Armored cables can be selected according to the site environment.
Neutral Input Line	Single-core outdoor copper wire	$\geq 16\text{mm}^2$	
Protective Ground Wire	Single-core outdoor copper wire	$\geq 16\text{mm}^2$	

Requirements for grid-connected leakage protection devices

Name	Residual Operating Current	Type	Rated Current
3P Leakage Protection Device (RCD)	100mA~300mA	Type B	$\geq 80\text{ A}$
This table describes the dimensions required for a single 3P leakage protection device (RCD) of WH-TIANWU-50-233B. For multiple units, the size should be appropriately increased on this basis.			

4.3 Installing the ESS and Cables

Precautions

 **DANGER**

- Before making any electrical connections, ensure that all switches in the ESS are in the "OFF" position. Otherwise, the high voltage of the ESS may cause electric shock hazards.
- Measure the voltage at the contact point before touching any conductor surface or terminal, and confirm that the protective grounding conductor of the equipment or parts to be repaired is securely grounded to ensure that there is no risk of electric shock.

 **WARNING**

- Equipment damage caused by improper wiring is not covered by the equipment warranty.
- Only qualified electricians can perform electrical connection operations.
- Operators must wear personal protective equipment when making electrical connections.

 **NOTE**

The cable colors shown in all electrical connection diagrams within this section are for reference only. Cables shall be selected according to local cable standards, with yellow-green dual-color wires reserved exclusively for protective grounding).

Installation Procedure

Step 1 Remove the packaging of the ESS.

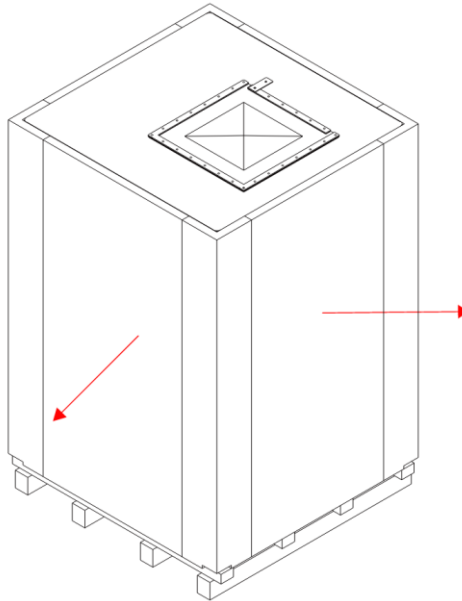

■ **Figure 4-1 Remove the packaging**

Step 2 Remove the front and rear cover plates.

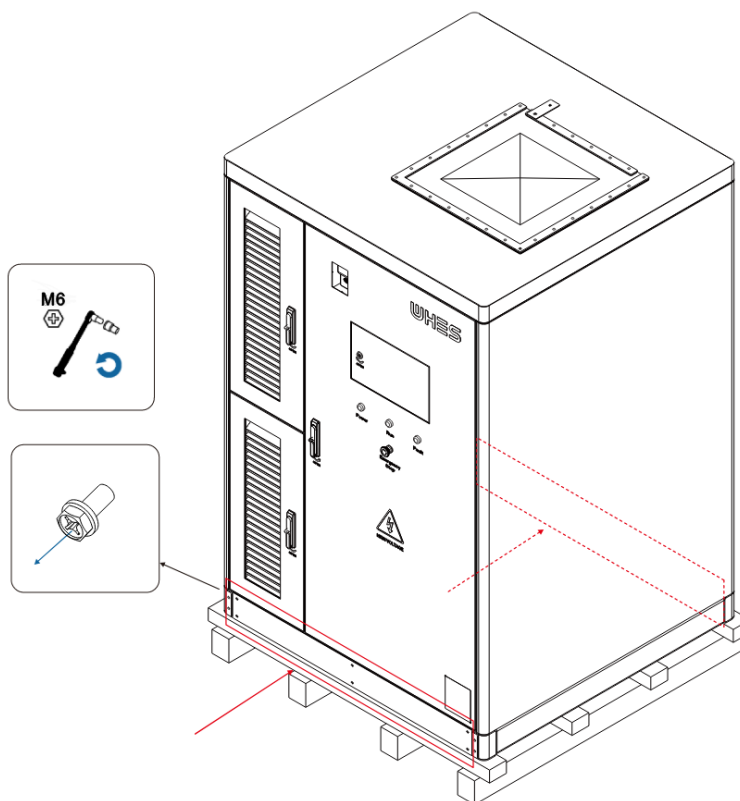

■ **Figure 4-2 Remove front and rear cover plates**

Step 2 Remove the pallets.

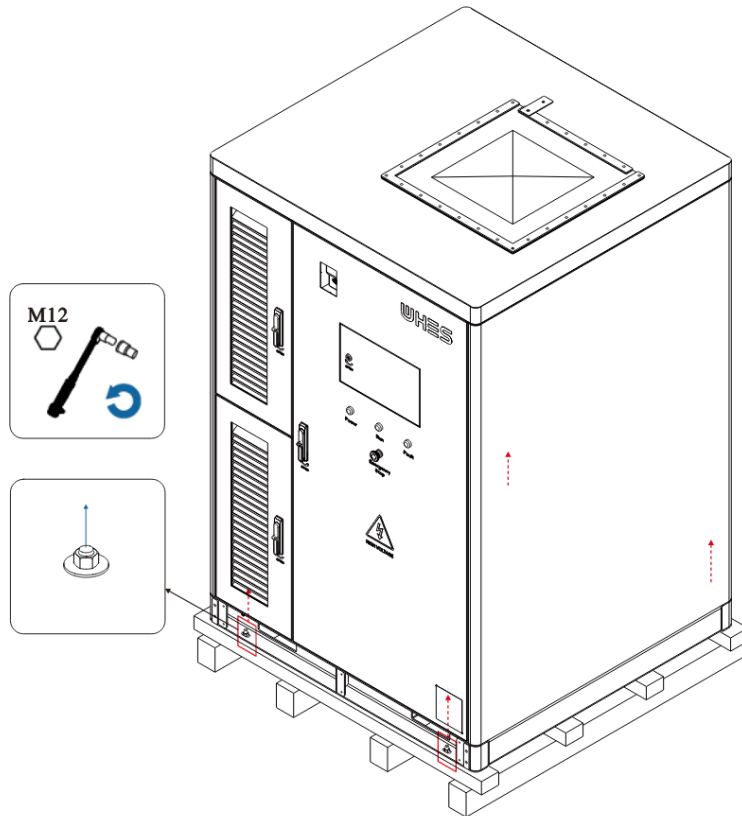

■ **Figure 4-2 Remove the pallets**

Step 3 Drill holes on the foundation and install expansion screws (M12×100, 4 pcs in total).

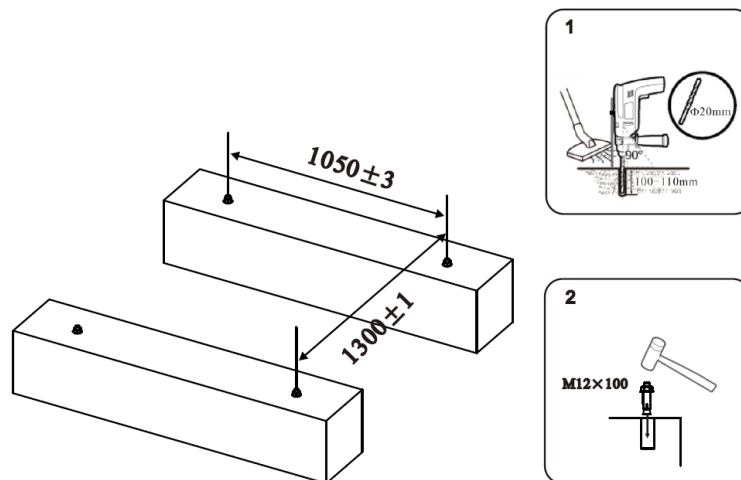

■ **Figure 4-3 Drill holes on the foundation and install expansion bolts**

Step 4 Move the cabinet to the mounting platform using a forklift.

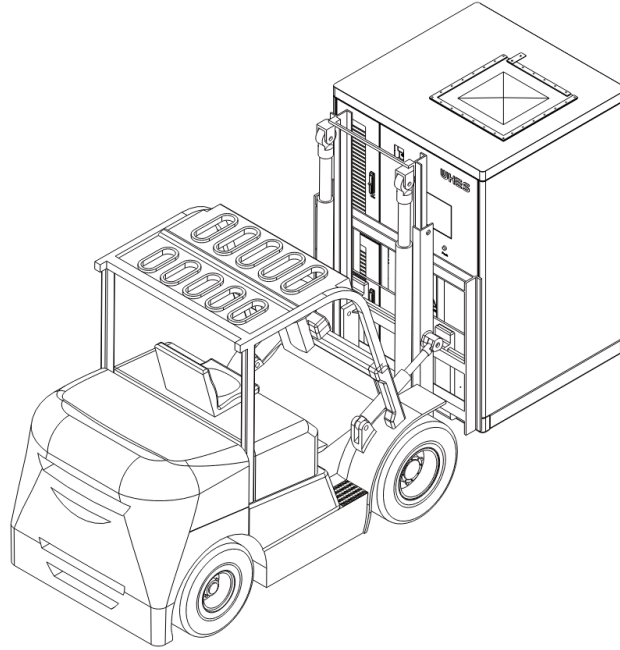

Figure 4-4 Move the ESS to the mounting platform using a forklift

BEWARE

When using a forklift to move the equipment, secure the equipment with appropriate straps based on the actual situation to prevent the risk of overturning.

Step 5 Fix the ESS.

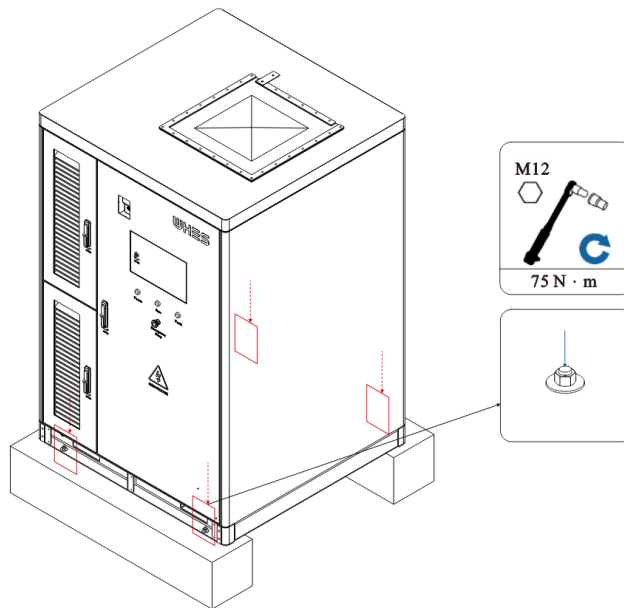

Figure 4-5 Fix the ESS on the mounting platform

Step 6 Install the grounding busbar as well as the front and rear cover plates.

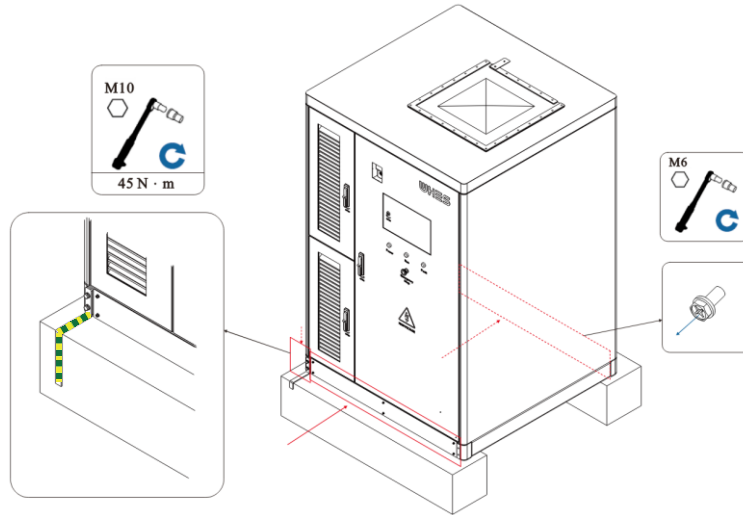

Figure 4-6 Install the grounding busbar as well as the front and rear cover plates
Step 8 Open the front door of the battery compartment.

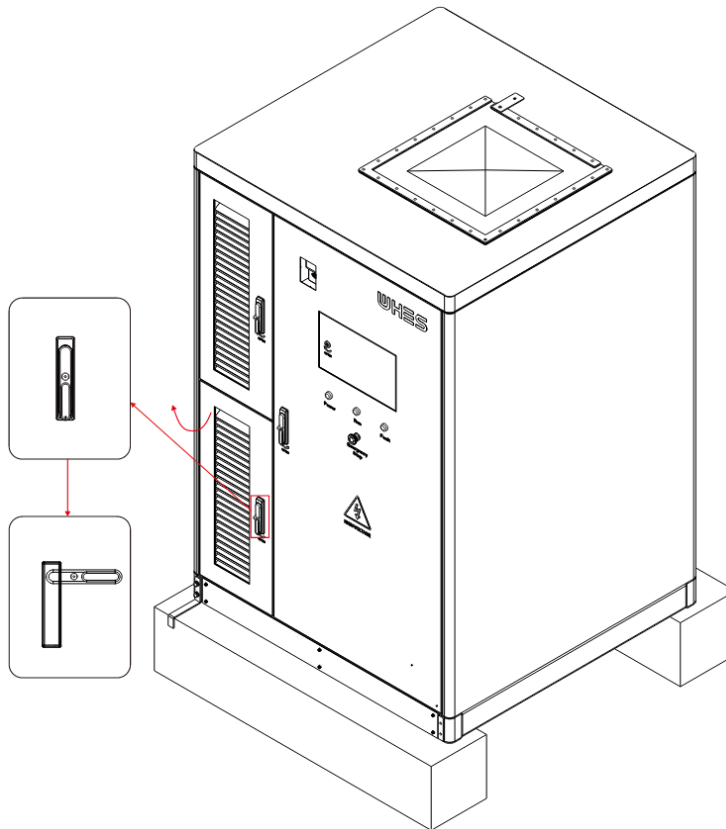

Figure 4-8 Open the front door of the battery compartment

Step 9 Install AC cables.

Warning

When the live parts of the equipment unintentionally conduct to the grounding system or grounded components due to insulation failure, a ground fault will be triggered. If such a fault is detected, the yellow indicator light on the device will remain continuously illuminated. When the yellow indicator light is observed, please stop all work immediately and disconnect the system. Otherwise, this may result in risks of electric shock, equipment damage, and electrical fire.

BEWARE

The color codes of AC cables shown in the figure below follows the European standard. For color codes applicable in other regions, please refer to Table 4-2: Color Codes of Three-Phase Wires.

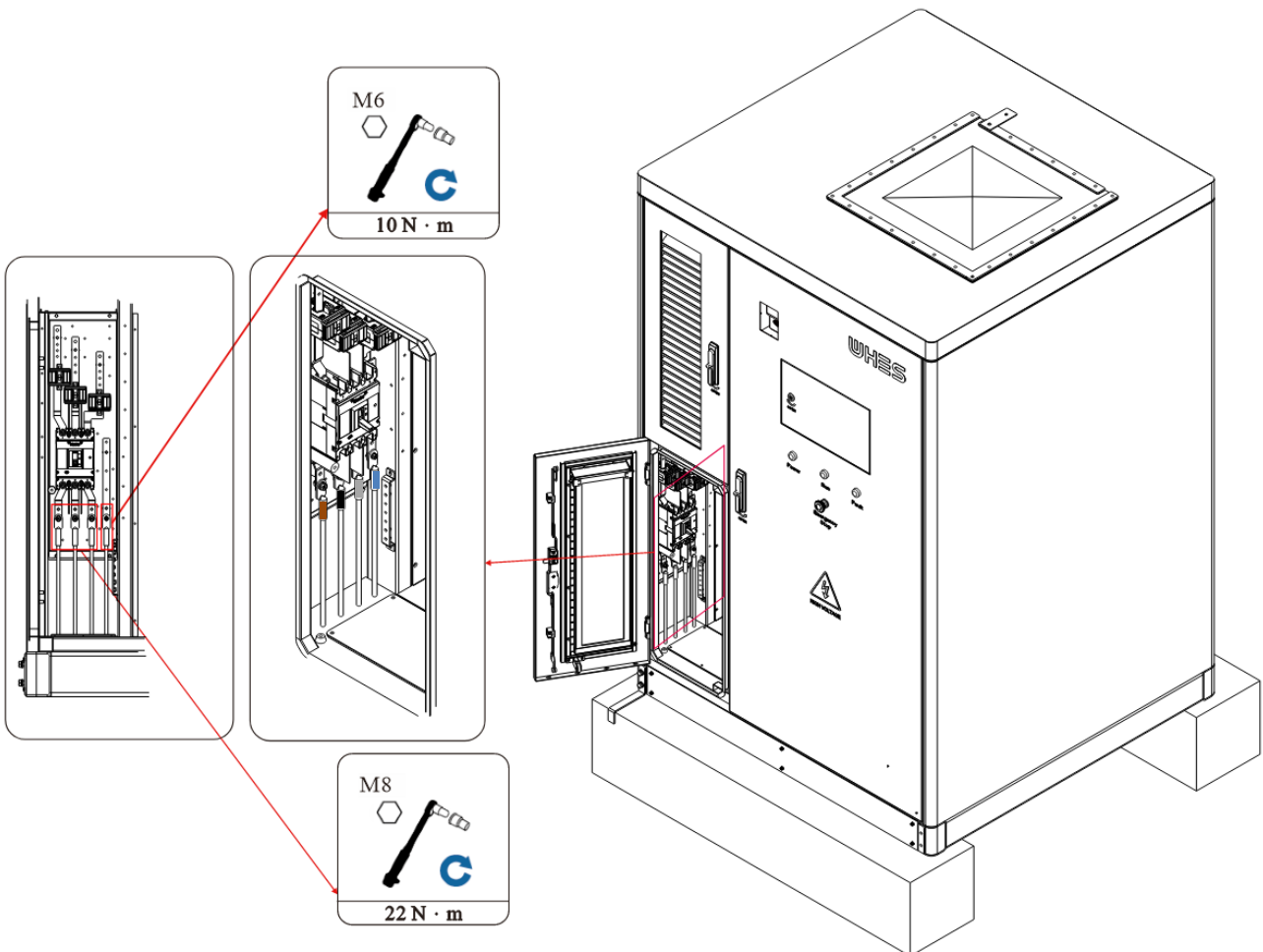

Figure 4-9 Install the power cables

Table 4-2 Color Codes of Three-Phase Wires

Region	L1	L2	L3	Neutral Wire	Ground wire	NOTE
Australia	Red	White	Blue	Black	Yellow-Green Stripes	<p>The table outlines the three-phase wire color requirements for various countries and regions worldwide. If the colors indicated in the table differ from those at the installation site, the latter shall prevail.</p>
China	Yellow	Green	Red	Blue	Yellow-Green Stripes	
America	Black	Red	Blue	Gray	Green	
Europe	Brown	Black	Gray	Blue	Yellow-Green Stripes	
Malaysia	Red	Yellow	Blue	Black	Yellow-Green Stripes	
India	Red	Yellow	Blue	Black	Green	

Step 10 Close the front door of the electrical compartment.

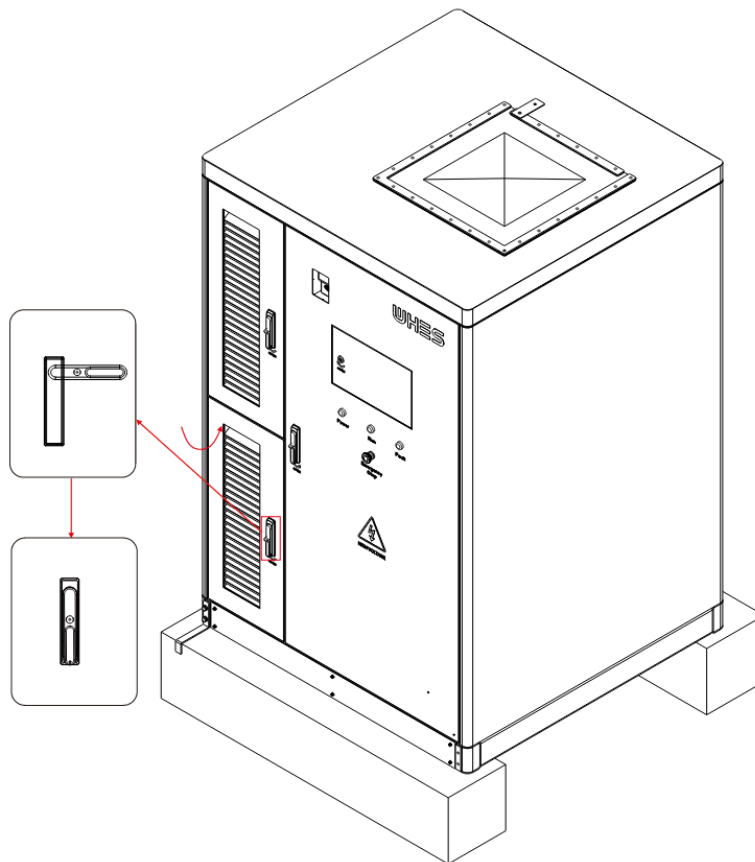

Figure 4-10 Close the front door of the electrical compartment

5 System Power-On/Off

5.1 Pre-Power-On Inspection

No.	Inspection Item	Acceptance criteria
1	Equipment Appearance	The equipment is intact and free of visible damage, rust, or peeling paint. Repaint any areas with peeling paint.
		All labels on the equipment are clearly visible and legible. Replace damaged labels promptly.
2	Cable Appearance	Cable protective layers are well wrapped and free of visible damage.
		Cable conduits/hoses are intact.
3	Cable Connection	Cable connections are correctly positioned according to the design.
		Terminals are properly installed in accordance with specifications, and connections are secure and reliable.
		All cables are clearly identified at both ends with legible labels that are oriented in a consistent manner.
4	Cable Routing	Cables are routed by separating strong and weak power systems.
		Cabling is organized in a neat and orderly manner.
		Cable ties are trimmed flush, eliminating sharp edges or protrusions.
		Bends are properly managed with sufficient slack, without over-tensioning cables.
		All cables are routed straight and smooth inside the cabinet, avoiding crossovers.
5	Switch	All circuit breakers in the power distribution cabinet are in the OFF position.
		All switches in the HV box are in the OFF position. (battery cabinet)

User Manual

6	Enclosure Grounding	Each enclosure has at least two securely connected grounding points with a maximum contact resistance of 0.1Ω.
7	Identification	Identification is correct, legible, and complete.
8	Sealing of Cable Openings	All cable openings are properly sealed.
9	Battery Pack	All battery pack are free of visible damage.
10	Foreign Objects	All foreign objects such as tools, and leftover installation materials are removed from the cabinet.
11	Power Distribution Area Cover Plate	The cover plates in the power distribution area are free of visible cracks, dents, scratches, breakage, or looseness.

5.2 Circuit Breaker Description

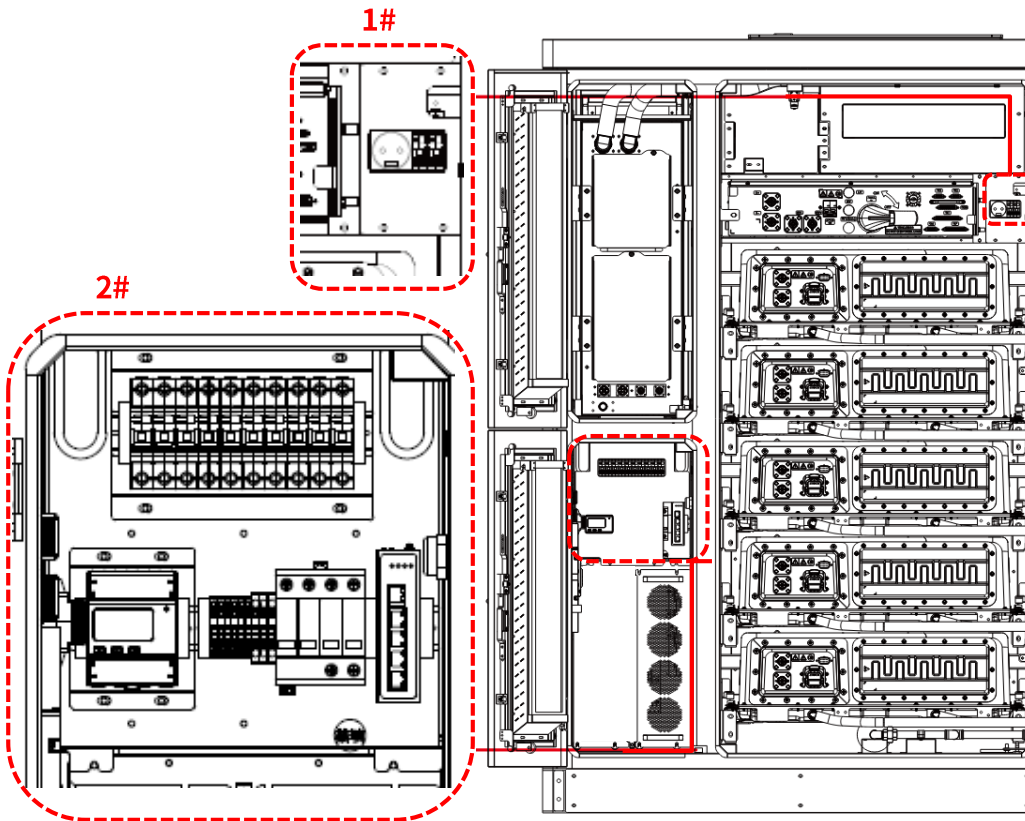

Figure 5-1 Circuit Breaker Position Diagram



The breaker described in Table 5-1, as shown in the figure, has circuit breakers arranged from left to right.

Table 5-1 Circuit Breaker List

No.	Name	Function
1#	MCB5	Commissioning socket ON/OFF switch
	MCB6	UPS power switch
2#	MCB1	Lightning arrester switch
	MCB2	Meter sampling switch
	MCB3	Main auxiliary power switch
	MCB4	Dehumidifier switch

5.3 Power-On Procedure

Table 5- 2 Power-On Procedure

Step	Item	Notes
1	Close the AC auxiliary power circuit breaker MCB3	Make sure to close the grid-connected AC circuit breaker QF first
2	Close MCB6 and turn on the UPS.	Press and hold ON/MUTE until you hear the power-on sound and the display shows ON.
3	Close the circuit breaker groups MCB1, MCB2 and MCB4 in sequence	
4	The energy storage battery cabinet is powered on.	Check if all equipment is powered on and pay attention to safety precautions.

Note a: Before closing the grid-connected AC circuit breaker QF of the ESS, verify that the power supply voltage on the grid-connected side is within the normal range (230V±10%).

 **BEWARE**

When equipment installation and commissioning are completed, there is no need to switch off the power supply to the system; simply follow the power-off procedure. If the equipment needs to be powered off for maintenance, please refer to 5.4 Power-Off Procedure in this section.

5.4 Power-Off Procedure

Table 5-3 Power-Off Procedure

Step	Item	Notes
1	Issue a power-off command in PANGU LITE to power off the DC side.	The system switches to shutdown mode. At this point, the main circuit of the electrical cabinet is disconnected and there is no longer any high voltage present at the positive and negative output terminals.
2	Open the circuit breaker groups MCB1, MCB2 and MCB4 in sequence	
3	Open MCB6 and turn off the UPS.	Press and hold ON/MUTE until you hear the shutdown sound and the display shows OFF. Now the UPS is turned off.
4	Open the AC auxiliary power circuit breaker MCB3	Disconnect the 230V auxiliary power supply main switch
5	Open the main AC circuit breaker QF	Power-off process completed

6 Power-On Commissioning (PANGU-LITE)

Prerequisites

1. All on-site equipment has been fully commissioned upon arrival.
2. The system has been successfully powered on, and all alarms have been cleared.
3. Commissioning devices for startup are available on site.

6.1 Preparation and PANGU LITE Access

Procedure

As shown in the figure, use the fixed operation display on the door panel to enter the PANGU-LITE screen.

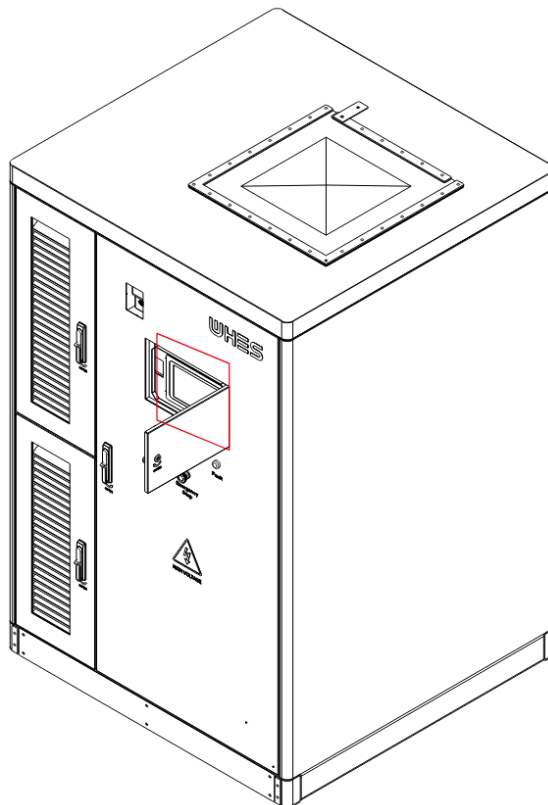

Figure 6-1 Diagram Wiring Diagram for Communication Cables

If the screen fails to appear automatically, open the browser and enter 133.144.155.10:8080/lite to access the PANGU-LITE screen.

6.2 Screen Description

Home Screen:

1. After accessing this screen, you can customize the language, time zone, display settings, and other parameters at the top right corner.
2. This screen shows the direction of energy flow in the energy storage system, as well as the real-time operating status of the PCS, battery and grid. The alarm/message system refreshes the operating status and data every 5s.
3. This flow shows the three-phase voltage and current of the grid, the power supply of the PCS, as well as the SOC, voltage and current of the battery.
4. PCS operating conditions:
 - Charging: Indicate that the equipment is charging.
 - Discharging: Indicate that the equipment is discharging.
 - Offline: Indicate that the equipment is in an offline state.
 - Standby: Indicates that the equipment is functioning normally without faults and is not in the charging or discharging process.
 - Inactive: Indicate that the equipment has stopped operating.

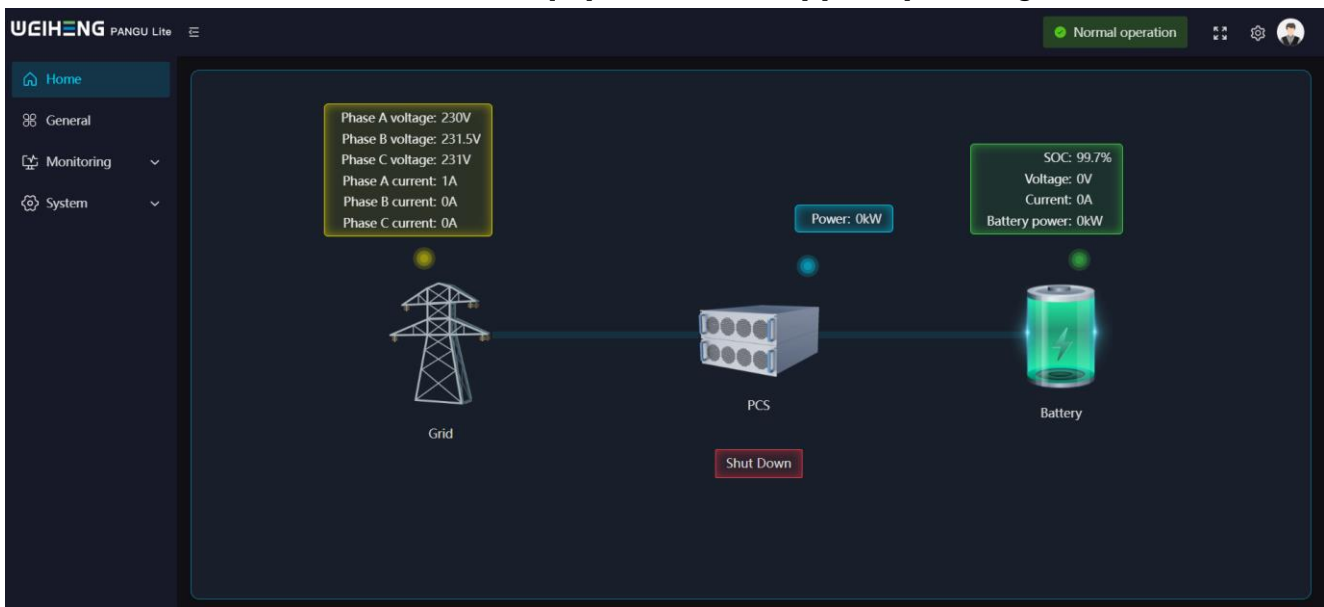

Figure 6-2 PANGU LITE - Home

Energy Storage Overview:

Display basic system information, including EMS-SN, rated power, rated capacity, maximum charge power, number of PCS units, number of battery clusters, charge/discharge power, available charge/discharge capacity, SOH, and SOC.

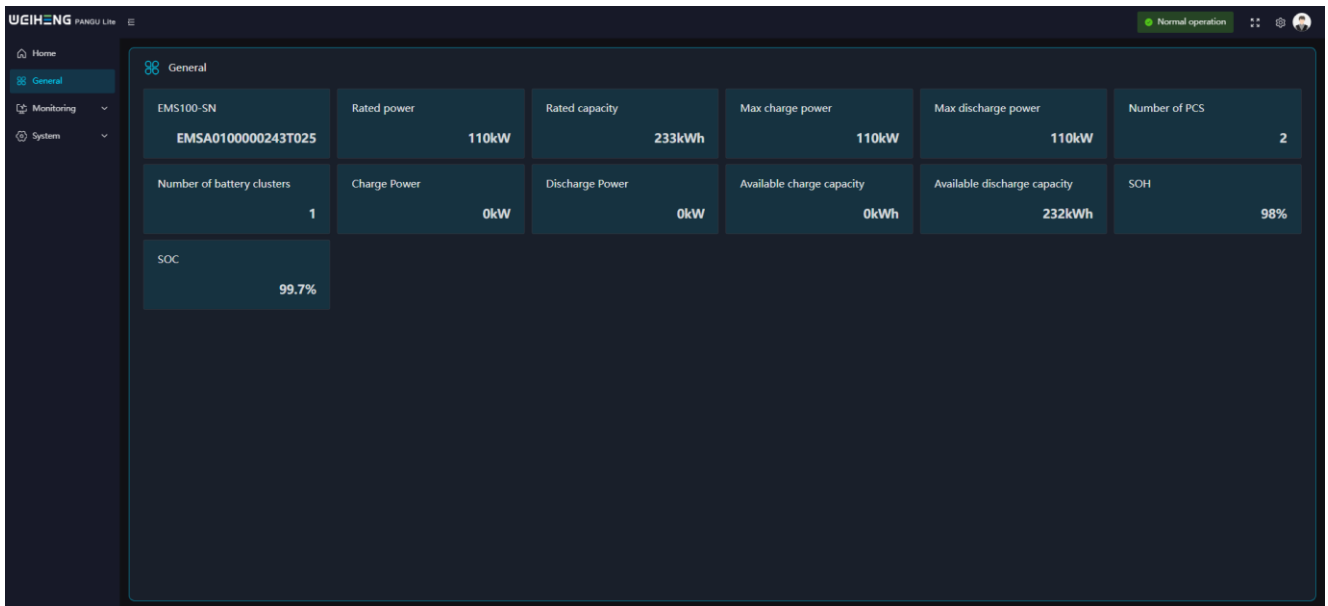

Figure 6-3 PANGU LITE – Energy Storage Overview

Operation Monitoring – PCS Screen:

This screen allows real-time monitoring of DC current, DC voltage, and three-phase voltage data, and monitors all operating conditions of the PCS. It also displays operating and simulated data of the PCS, including design capacity, maximum and minimum design voltage, frequency, power factor, active power and reactive power.

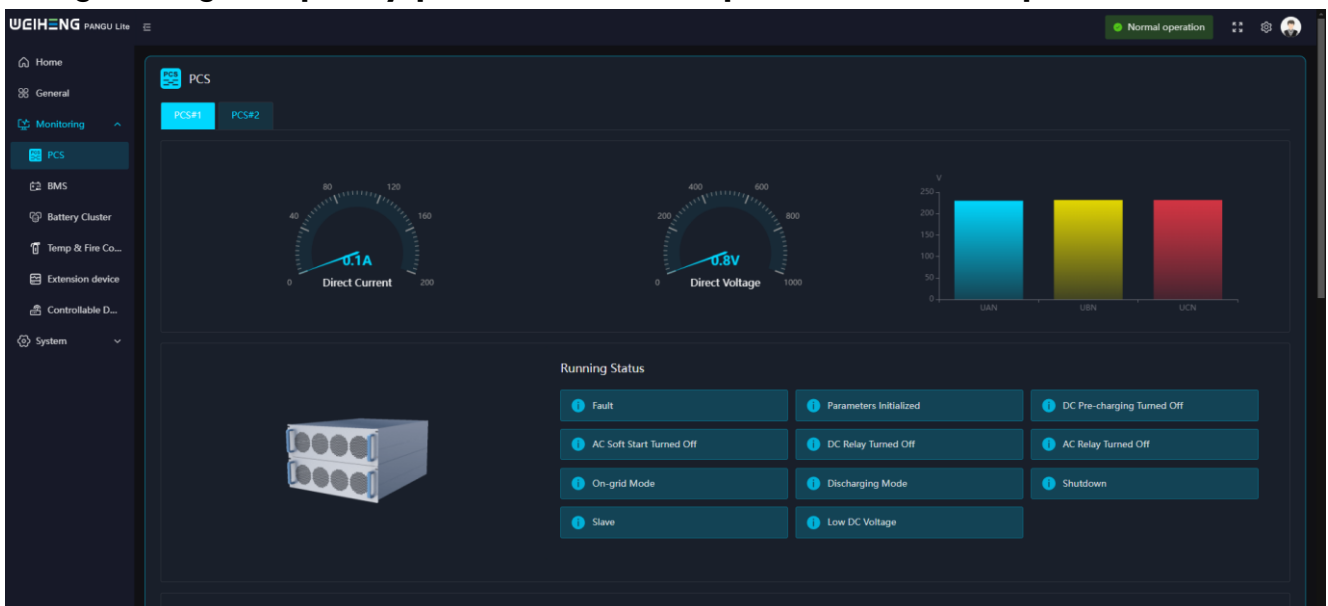

Figure 6-4 Operation Monitoring – PCS Screen

Operation Monitoring – BMS Screen:

This screen displays SOC/SOH monitoring information, operating status, and detailed operating data for the battery BMS. It also displays real-time status and data for all battery clusters.

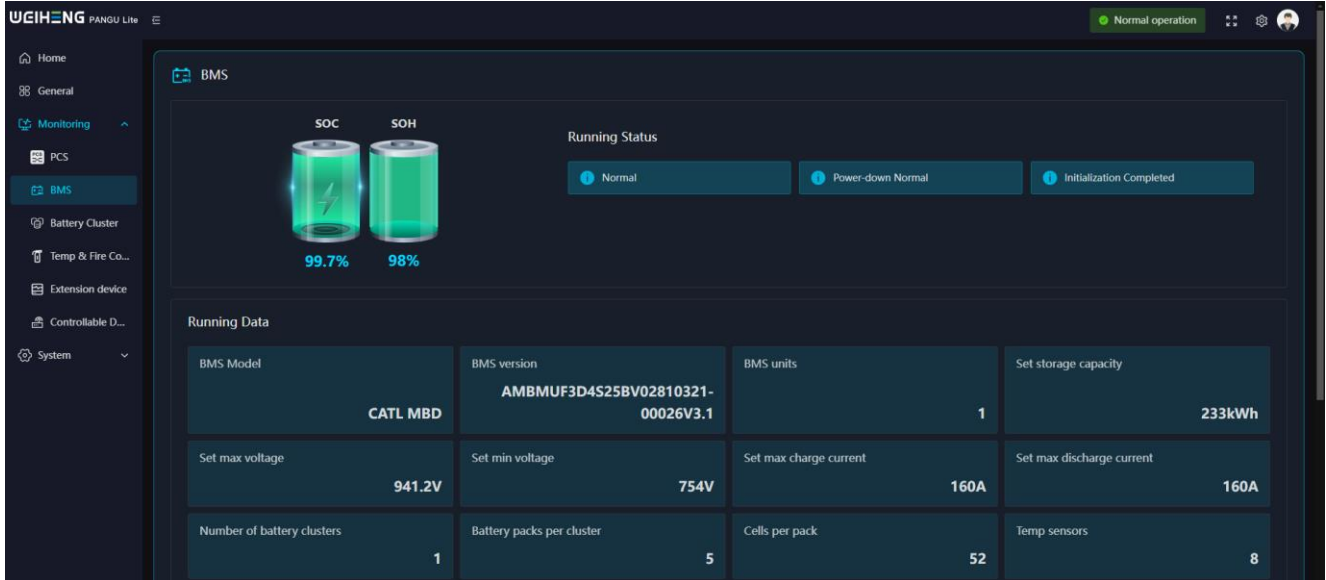

Figure 6-5 Operation Monitoring – BMS Screen

Operation Monitoring – Battery Cluster Screen:

This screen monitors the voltage and temperature of each battery in the pack, as well as all operating data for the entire battery cluster.



Figure 6-6 Operation Monitoring – Battery Cluster Screen

Operation Monitoring – Temperature Control & Fire Safety Screen:

This screen monitors the inlet and outlet water temperature, pressure and operating status of the water cooling system, as well as the operating status of the air conditioning and fire protection systems.

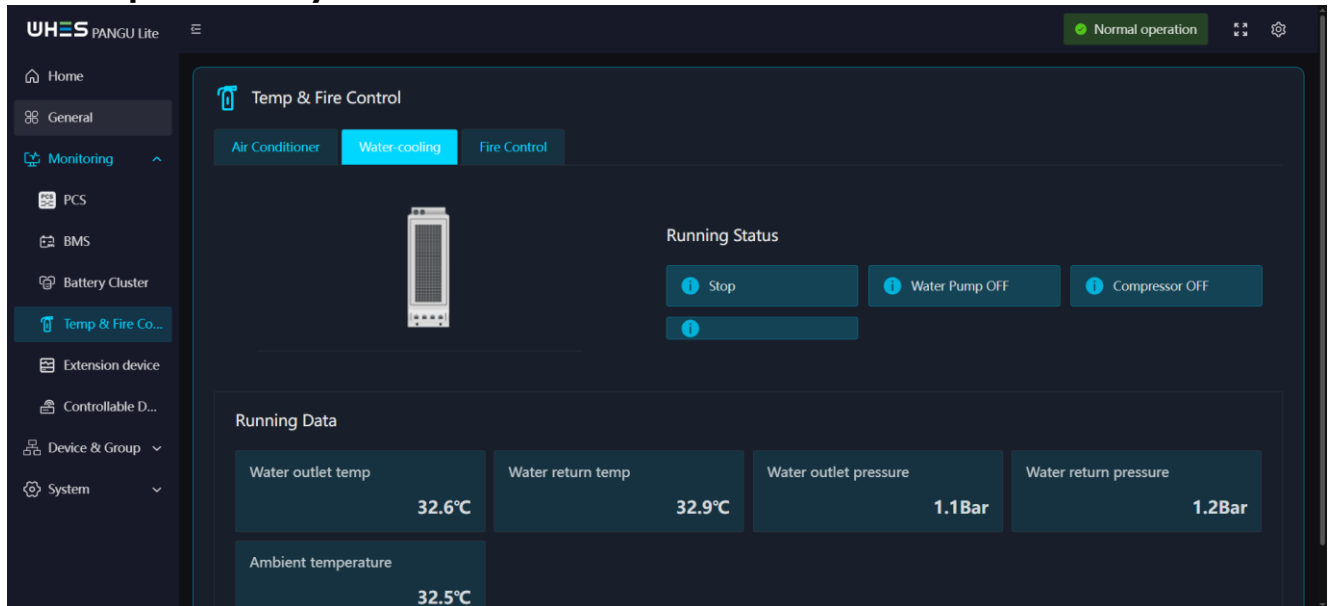

Figure 6-7 Operation Monitoring – Air Conditioning & Fire Protection Screen

System Configuration – System Status Screen:

This screen allows you to view the system operating status and perform system control.

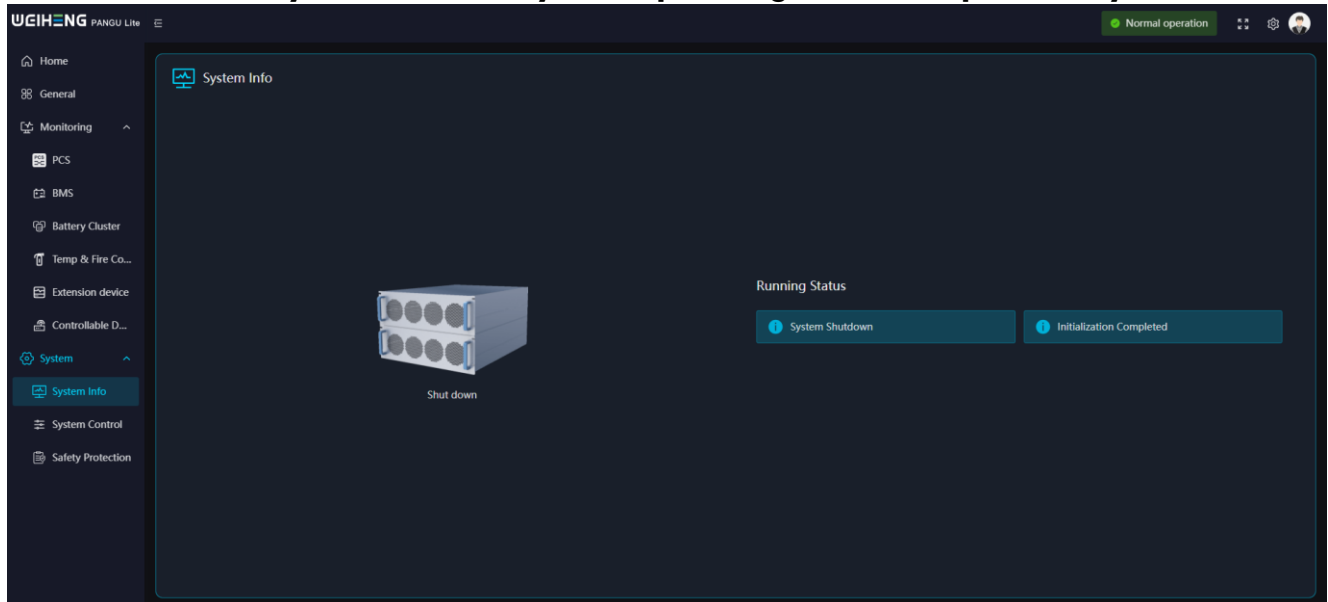

Figure 6-8 System Configuration – System Status Screen

System Configuration – System Control Screen:

This screen allows you to control the energy storage system, including the system switch, reset, grid switch, control mode, SOC lower discharge limit, power factor, power control, and coordination control switch.

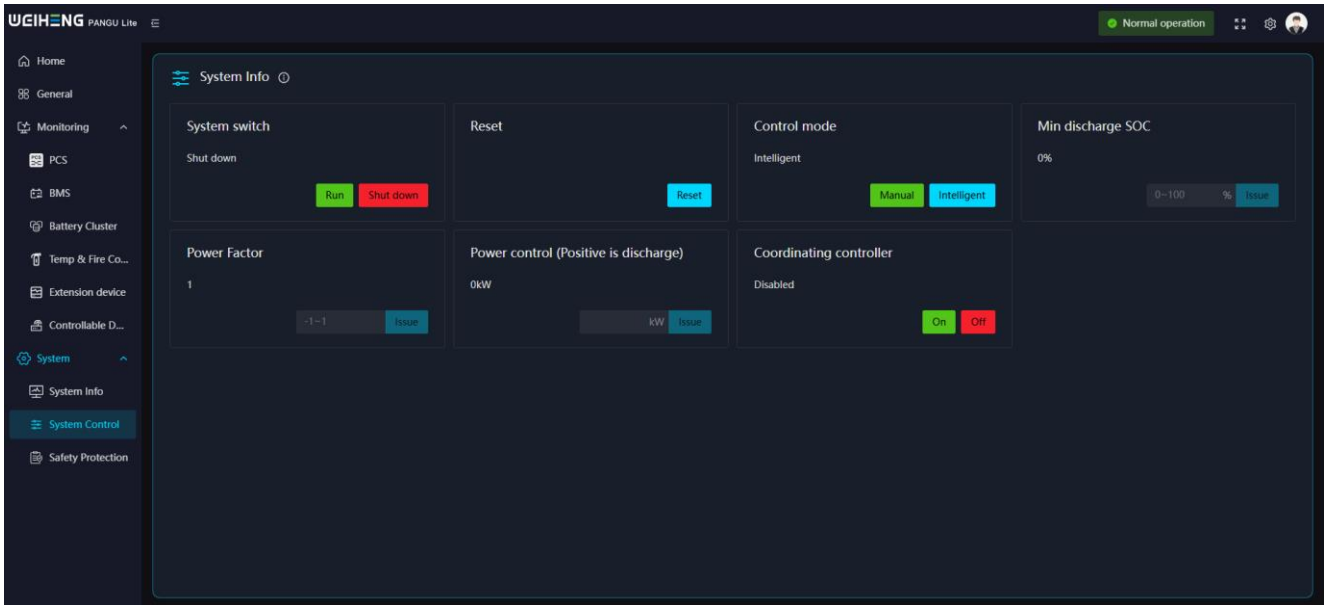
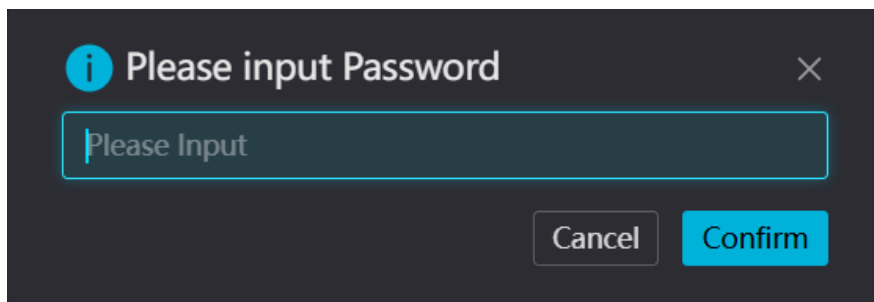

Figure 6-9 System Configuration – System Control Screen

6.3 Startup Procedure

Operation Procedures

When entering the device control-related module, a password is required. The default password is "123456". Please change the initial password as soon as possible after entering to ensure the device's security.



Step 1: Navigate to "System Configuration > System Control", click the "Start" button, and verify that the equipment status has been switched to on-grid mode.

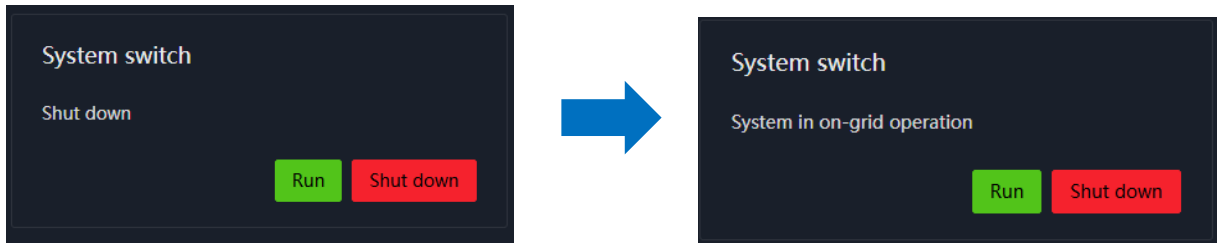

Step 2: Check the "Home" screen to verify that the PCS is in standby mode.

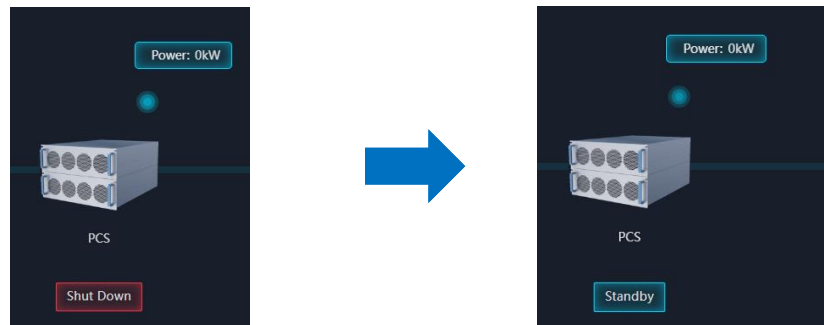

Step 3: Navigate to "System Configuration > System Control", enter -10 kW in the "Power Control" module, and click the "Apply" button.

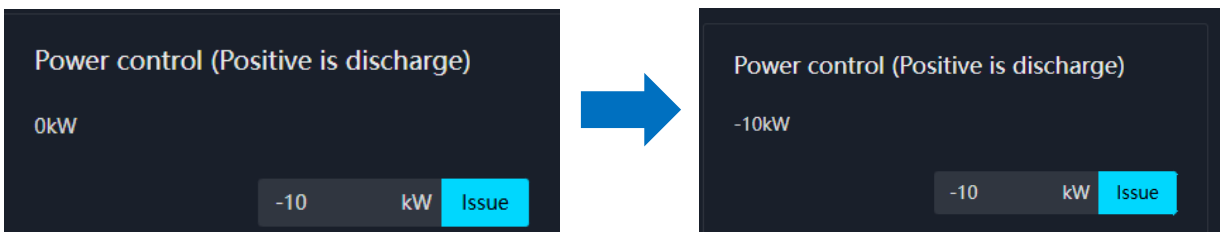

Step 4: Check the "Home" screen to verify that the PCS is in charging mode, and view the real-time display of system operating power.

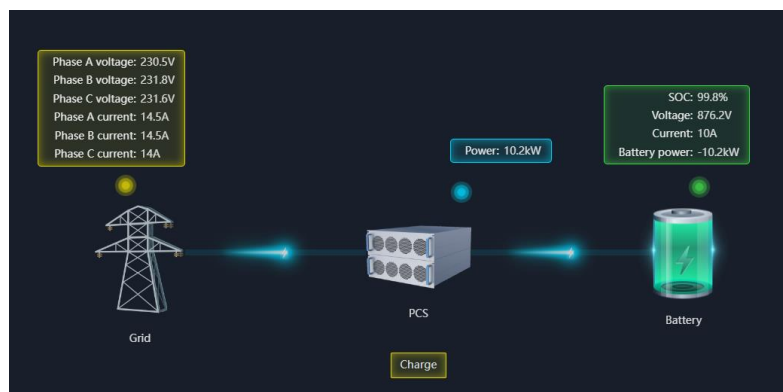

6.4 Shutdown Procedure

Operation Procedures

Step 1: Navigate to "System Configuration > System Control", enter 0 kW in the "Power Control" module, and click the "Apply" button.

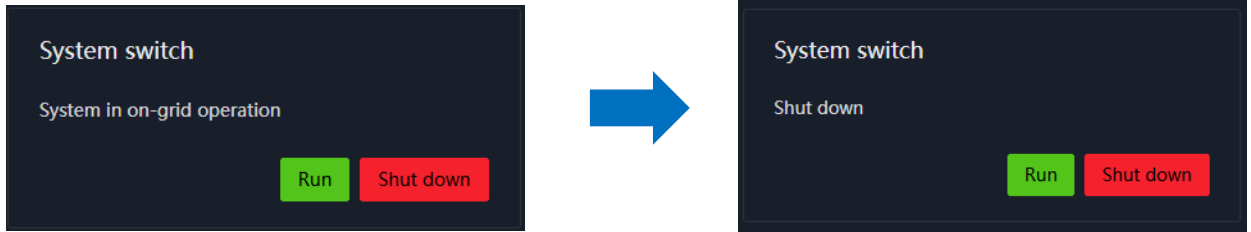

Step 2: Check the "Home" screen to verify that the PCS is in standby mode.



Step 3: Navigate to "System Configuration > System Control", click the "Stop" button, and verify that the equipment status has been switched to inactive mode.

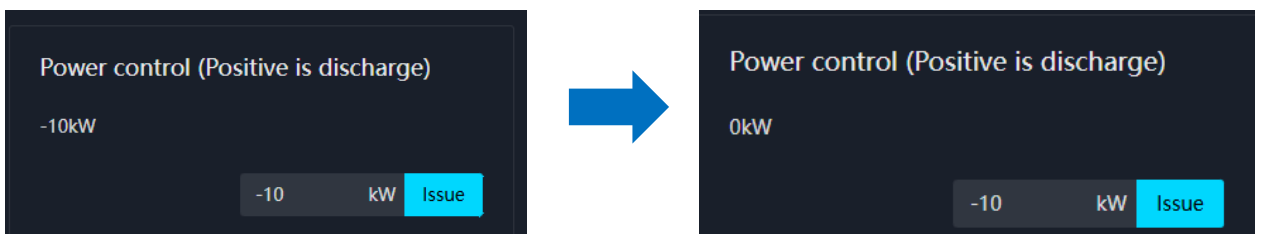

Step 4: Check the "Home" screen to verify that the PCS is in inactive mode, indicating that the equipment has been shut down.

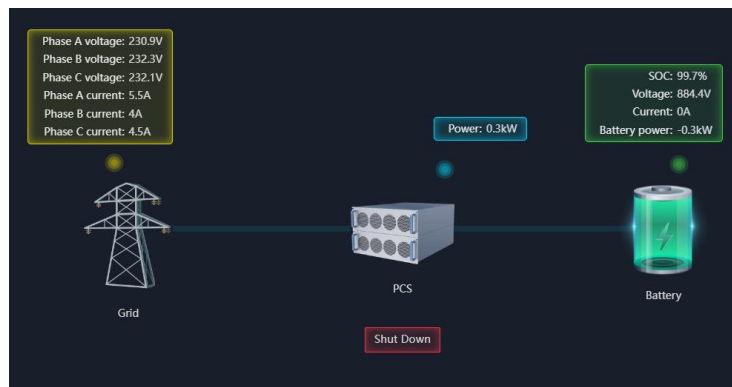

7 Technical Data

Model	WH-TIANWU-50-233B
Battery Side Parameters	
Rated Capacity (kWh)	233
Rated Voltage (VDC)	832
Voltage Range (VDC)	728-936
Battery Type	LFP(LiFePO4)
Cell Specifications	3.2V/280Ah
Module Specifications	1P260S
AC Parameters (Grid-Connected)	
Rated Power	50kW
Max. Output Power	50kW
Rated Output Power in VA	50kVA
Rated Output Current	72A
Rated Voltage AC	400V,3P+N+PE
Rated Frequency AC	50Hz
Max. THD of Current	<3%
Power Factor	-1~+1
Basic parameters	
Protection grade	IP55
Working temperature	-20~55°C (derating above 45°C)
cooling method	Air cooling (PCS); Liquid cooling (battery)
Overvoltage Category(OVC)	II for DC Side III for AC Side
Environmental Relative Humidity	0~100%
Maximum Operating Altitude	2,000 m
Communication interface	Modbus TCP/IP
Noise Level	<75dB
Dimensions (W*D*H)	1400*1360*2100mm
Weight (kg) including battery	~2700

Note

The products are only intended for premises with a power supply capacity of ≥ 50 A per phase, supplied from a distribution network with a nominal voltage of 400/230 V.

8 Product Maintenance

8.1 Terminology Definition

- **Normal operation:** Refers to a system that operates daily.
- **Intermittent operation:** Refers to a system that operates at an irregular monthly frequency and cannot guarantee daily operation.
- **Long-term storage:** Refers to a battery system that has not been activated for more than 5 consecutive months (the battery system should be charged to 50% SOC before suspending use).

8.2 Requirements for Normal System Operation

- Perform battery maintenance on the system every 12 months to prevent battery damage. Refer to Section 9.6 for specific maintenance instructions.
- Conduct a patrol inspection for the ESS every 12 months (refer to Appendix 1) and maintain inspection records.

8.3 Requirements for Intermittent System Operation

- The requirements are the same as those for normal operation of the system.

8.4 Requirements for Long-Term System Storage

- Energy storage battery storage SOC range: 30%~50%. Avoid long-term storage of cells below 15% SOC. When batteries are not used for a prolonged time, disconnect power-consuming devices promptly.
- Conduct a patrol inspection for the ESS every 5 months (refer to Appendix 1) and maintain inspection records.
- Perform battery maintenance on the system every 5 months to prevent battery damage. (Refer to Section 9.6 for specific maintenance instructions).
- Before the first use of a long-term stored system, perform at least one full charge cycle to activate the battery system and restore battery performance to its optimal state.

Tips

If the energy storage system is not used for a long time, it will cause irreversible damage to the battery. Please perform regular maintenance.

8.5 Isolating switch Function

a) Isolating switch is a manually operated electrical component used to disconnect HV lines and provide safety protection (see diagram on the right).

b) Prior to system maintenance, always turn off the Isolating switch first. After completing maintenance work, ensure the switch disconnector is in the ON position.

Operation Under Load is
Strictly Prohibited

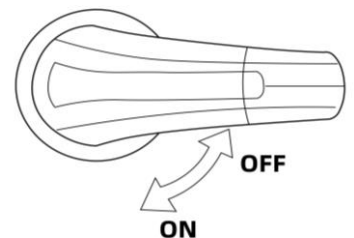
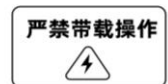

8.6 Battery Maintenance Instructions

To ensure the safe and reliable long-term operation of your ESS, please read and follow the instructions below:

Maintenance Procedure:

Scheme 1: This power saving scheme is recommended when the battery system is at a low SOC level.

1. Discharge the battery system to the cut-off condition (average cell voltage $<3.1\text{ V}$ or minimum voltage $<2.8\text{ V}$), then stop discharging and let it rest for 1 h.
2. Perform an automatic full charge on the battery system (maximum cell voltage $>3.65\text{ V}$). After charging is complete, let it rest for 1 h.
3. Discharge the battery system to 50% SOC and then stop discharging.

Scheme 2: This power saving scheme is recommended when the battery system is at a high SOC level.

1. Perform an automatic full charge on the battery system (maximum cell voltage $> 3.65\text{ V}$). After charging is complete, let it rest for 1 h.
2. Discharge the battery system to the cut-off condition (average cell voltage $<3.1\text{ V}$ or minimum voltage $<2.8\text{ V}$), then stop discharging and let it rest for 1 h.
3. Charge the battery system to 50% SOC and then stop charging.

Tips

1. Check to ensure environmental safety, system safety, no alarm, no fault before performing maintenance operations.
2. After the battery maintenance of ESS is completed, you can notify our after-sales engineer to perform data analysis for free.

8.7 Liquid Cooling System Maintenance and Service Requirements

- a) The coolant recommended by WHES is SoluKing SK-E50-B -40°C.
- b) It is strictly forbidden to inspect or repair the unit while it is energized. Wait more than 15 min after the unit is powered off before repairing or disassembling the unit.
- c) Third-party coolants not approved by Whes are not recommended. If used, they must comply with the coolant standards specified in Table 9-1. Damage to the battery cabinet components caused by using coolants other than those recommended by Whes will not be covered by the warranty.
- d) The coolant is typically an alkaline solution, and its alkalinity will gradually diminish over time with use. It is recommended to check the coolant concentration every six months. If the pH falls below 6, please consult our customer service for assistance.
- e) Use disposable pH test strips for testing. Immerse the strip in the coolant for 0.5 s, then remove it and compare it to a standard color chart to determine the pH value.
- f) The coolant sample for testing can be collected by inserting an 8 mm OD tube into the inspection port shown in Figure 9-1.
- g) Sampling should be performed with the system powered off, and 20–30 mL of coolant is required for a single test. Excessive discharge of coolant may result in insufficient fluid in the chiller, which may affect normal operation.

Table 8-1 Coolant Requirements

Parameters	Value
pH	7.5-8.5
Conductivity	200-3000 $\mu\text{S}/\text{cm}$
Evaporation Residue	< 500 mg/dm^3
Deposition	< 3 mg/dm^3
Ca + Mg	0.5-2 mmol/l
Bicarbonate	1-5 mmol/dm^3 (60-300 mg/dm^3)
Free Carbon Monoxide	< 10 mg/dm^3
Sulphide	< 0.01 mg/dm^3
Chlorides	< 50 mg/dm^3
Sulphates	< 250 mg/dm^3
Nitrates	< 25 mg/dm^3
Nitrite	< 0.1 mg/m^3

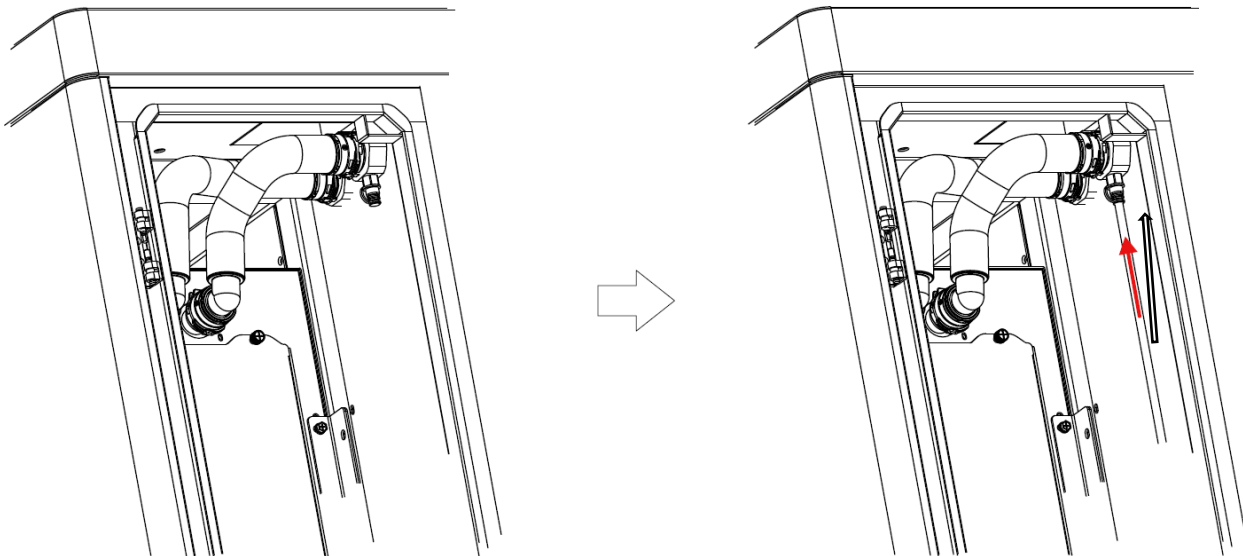

Figure 8-1 Coolant Inspection Port

A Crimping OT/DT Terminals

OT/DT Terminal Requirements

- For copper core cables, please use copper terminals.
- For copper-clad aluminum cables, copper terminals are required.
- For aluminum alloy cables, use copper-aluminum transition terminals, or aluminum terminals with copper-aluminum transition pads.

BEWARE

- It is strictly forbidden to connect aluminum terminals directly to terminal blocks, as this may cause electrochemical corrosion and affect the reliable cable connection.
 - When using copper-aluminum transition terminals, or aluminum terminals with copper-aluminum transition pads, ensure compliance with IEC61238-1.
 - When using copper-aluminum transition pads, ensure proper orientation so that the aluminum side of the pad contacts the aluminum terminal, and the copper side contacts the terminal block.
-

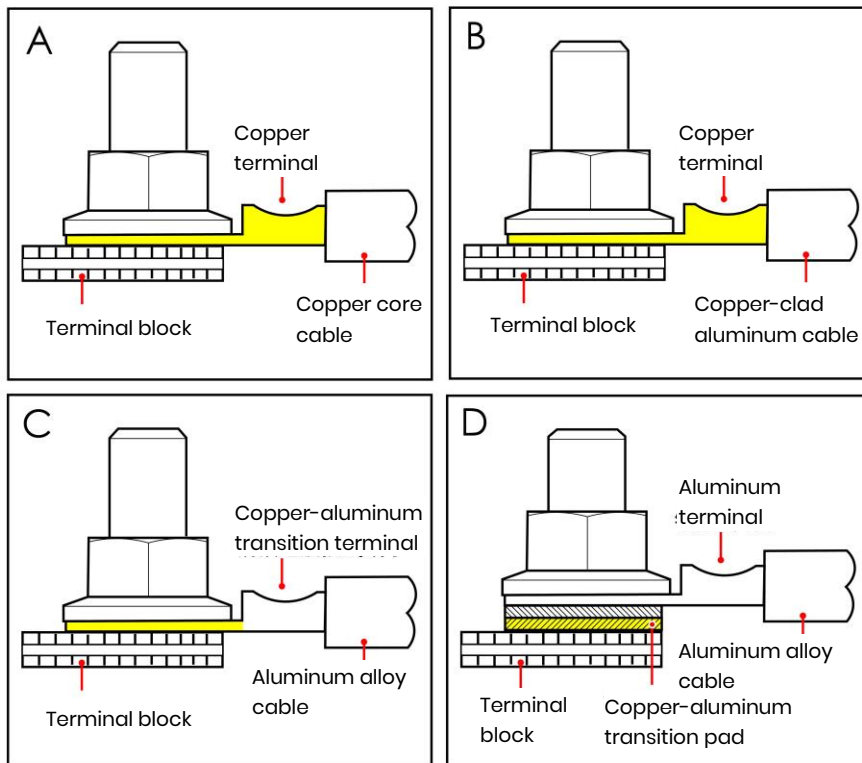

Figure A-1 OT/DT Terminal Requirements

Crimping OT/DT Terminals

BEWARE

- Do not scratch the conductor when stripping the cable.
- The cavity formed by the conductor crimping tab of the OT/DT terminal after crimping shall completely enclose the conductor, and the conductor shall be tightly connected to the OT/DT terminal without any looseness.
- The crimped area can be covered with heat shrink tubing or insulating tape. Below is an example of using heat shrink tubing.
- When using a heat gun, pay attention to safety precautions to prevent damage to the equipment.

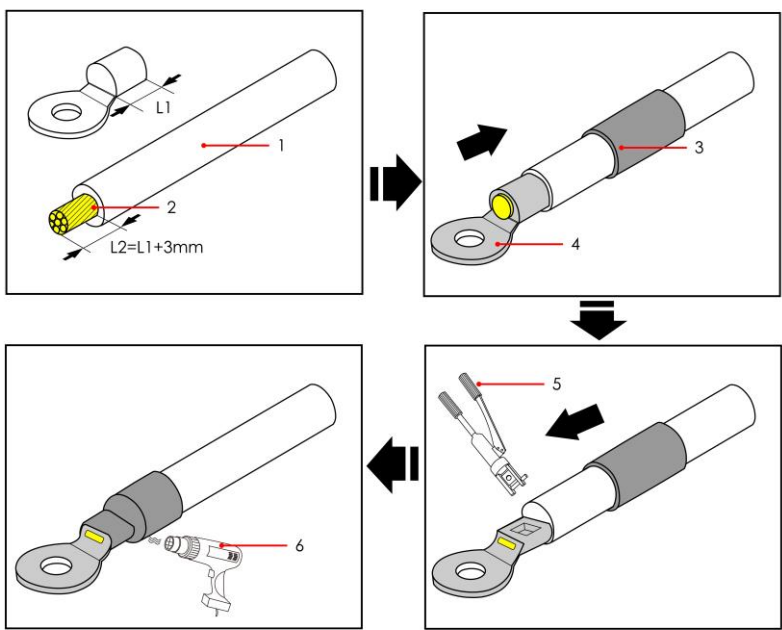

Figure A-2 Crimping OT Terminal

- | | | |
|------------------------|--------------------------------------|-------------------------------|
| (1) Cable | (2) Conductor | (3) Heat shrink tubing |
| (4) OT terminal | (5) Hydraulic crimping pliers | (6) Heat gun |

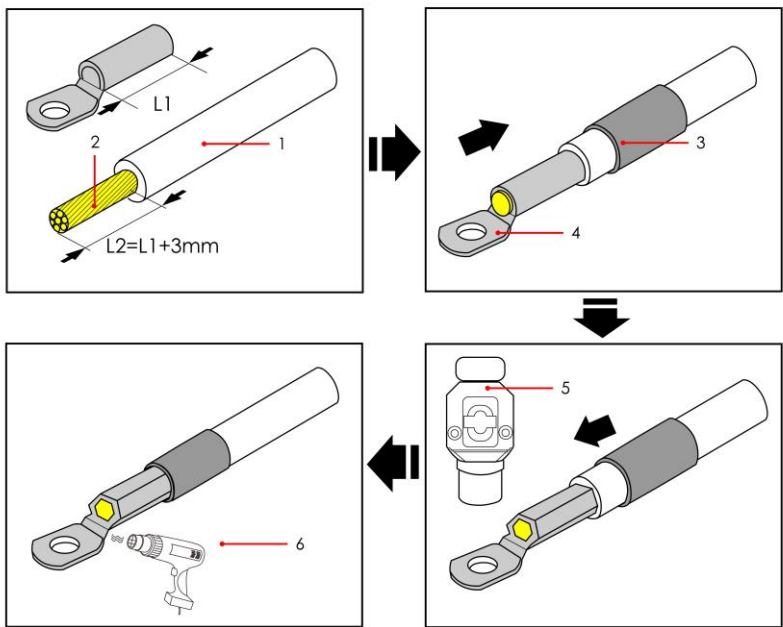

Figure A-3 Crimping DT Terminal

- | | | |
|------------------------|-------------------------------|-------------------------------|
| (1) Cable | (2) Conductor | (3) Heat shrink tubing |
| (4) DT terminal | (5) Hydraulic crimping | (6) Heat gun |

B How to Repaint

Prerequisites

- Repainting outdoors without shelter is strictly prohibited in severe weather conditions such as rain, snow, strong winds, sandstorms.
- The paint required for repainting has been prepared according to the color chart delivered with the equipment.

Cabinet Color

- Top cover and base: RAL 7046, small orange peel texture
- Enclosure and other sheet metal parts: RAL 7035, small orange peel texture

Repainting Instructions

Maintain the intact appearance of the equipment by repainting any paint loss immediately.



Visually inspect the extend of paint damage and prepare the necessary tools and adequate materials according to actual needs on site.

Table A-1 Repainting Instructions

Paint Damage	Tools & Materials	Procedure	NOTE
<p>Shallow scratches (without exposure of steel substrate)</p> <p>Non-wipeable stains and rust</p>	<p>Hand spray paint or paint, brush (for small area repainting), fine sandpaper, anhydrous ethanol, cotton cloth, spray gun (for large area repainting).</p>	<p>Follow Steps 1 + 2 + 4 + 5.</p>	<p>1. Use the color chart delivered with the equipment to match the topcoat (acrylic paint) color to the specified Pantone number.</p> <p>2. For minor scratches, small stains, and rust, hand spray or brush painting is recommended.</p>
<p>Deep scratches (primer damaged, steel substrate exposed)</p>	<p>Hand spray paint or paint, zinc-rich primer, brush (for small area repainting), fine sandpaper, anhydrous ethanol, cotton cloth, spray gun (for large area repainting).</p>	<p>Follow Steps 1 + 2 + 3 + 4 + 5.</p>	<p>3. For extensive scratches, large stains and rust, use a spray gun to apply the paint.</p>
<p>Logo and pattern damage or dents</p>	<p>For damaged logos and patterns, provide the logo dimensions and color code, and contact a local advertising and painting service provider to develop and execute a repair scheme based on the logo dimensions, color and damage situation.</p> <p>1. For dents with an area less than 100 mm² and a depth less than 3 mm, fill them with unsaturated polyester resin putty (Poly-Putty base) and then follow the repainting procedure for deep scratches.</p>		<p>4. Apply a thin, even coat of paint where practical, avoiding droplet formation and ensuring a smooth surface.</p> <p>5. Allow the repainted surface to dry for approximately 30 min before</p>

	2. For dents with an area greater than 100 mm² or a depth greater than 3 mm, find a local supplier to provide a separate repair scheme based on the actual situation.	proceeding with subsequent operations.
--	---	---

Cabinet color number standard

Table B-2 Paint repair

Unit	Colour number
Top cover, base	RAL7046 small orange pattern
Shell, other sheet metal parts	RAL7035 small orange grain

Operation Procedure

Step 1 Gently grind the damaged area with fine sandpaper to remove dirt or rust.

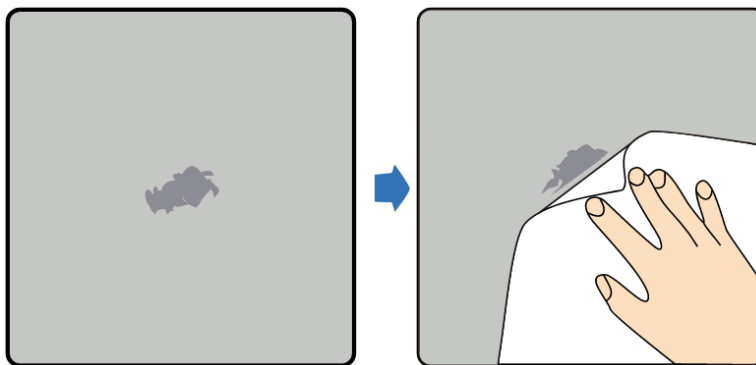

■ Figure B-1 Grind the damaged area with fine sandpaper

Step 2 Wet the cotton cloth with anhydrous ethanol, wipe the sanded area or the area to be repaired to remove surface dirt and dust, and then wipe dry with clean cotton cloth.

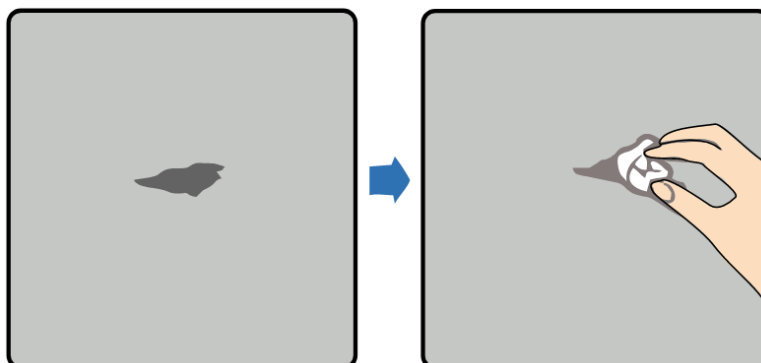

■ Figure B-2 Treat the damaged coating with anhydrous ethanol

Step 3 Apply zinc-rich primer to the damaged area with brush or spray gun

 NOTE

- If the substrate is exposed in the area to be repaired, an epoxy zinc-rich primer must be applied first until the substrate is not exposed after the paint is dry, and then an acrylic top coating should be applied.
- Select an epoxy zinc-rich primer or an acrylic top coating of the corresponding color according to the top coating color of the equipment.

Step 4 Select one of the methods of spray painting, brush painting, spray gun spraying according to paint defect degree to evenly repaint the damaged area until the coating defect is not visible.

 NOTE

- It should be noted that the paint film should be as thin and uniform as possible, the paint film should not be droplet shaped, and the surface should be smooth.
- If the patterns on the equipment use multiple colors, use tape and white paper to cover the parts of other colors other than the damaged paint before repainting to avoid contamination of other color parts during repainting operation.

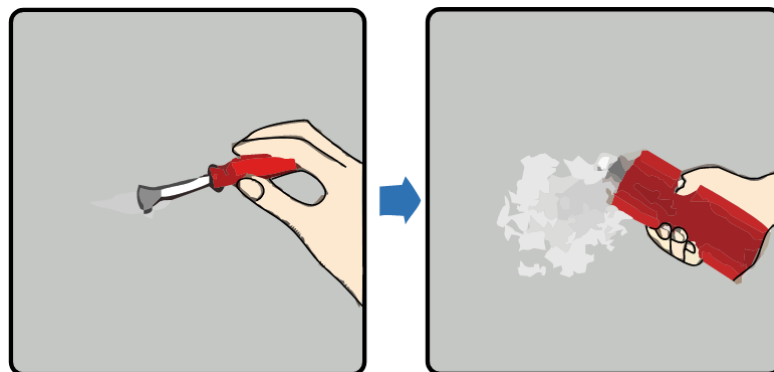

 Figure B-3 Repainting on damaged coating

Step 5 Upon completion of painting, leave the equipment rest for about 30 minutes, and then check whether the painting area meets the requirements.

 **NOTE**

- The repainted area must match the color of the surrounding area. Use a colorimeter to measure the color difference ($\Delta E \leq 3$). If a colorimeter is unavailable, visually inspect the repainted area to ensure a seamless blend with the surrounding area, free of any visible edge. The coating must be free of bumps, scratches, peeling, or cracks.
- For spray painting, it is recommended to spray three coats and then observe whether it meets the requirements. If not, repeat the spraying process until the requirements are met.

C How to Recycle Used Batteries

 **BEWARE**

- Whes does not provide battery recycling services. Customers are responsible for contacting local recyclers for disposal.
 - If no local service is available, customers are advised to contact the nearest national recycler for disposal.
-

Step 1 Contact the nearest recycler.

Step 2 The recycler evaluates the recycling cost.

Step 3 The recycler recycles batteries using one of the following two methods:

- **On-site recycling:** The recycler collects lithium batteries from the customer site, at a price determined based on the actual travel distance/transportation cost and other factors.
- **Centralized recycling:** The customer brings all lithium batteries to be recycled to a designated location for centralized collection by the recycler.

 **NOTE**

Transportation cost arising from the on-site recycling service is to be borne by the customer.

Step 4 The recycler is fully responsible for the disposal of the recycled batteries. The recycler takes full responsibility for disposing of the recycled lithium batteries, with no further involvement from the customer.

D Contact Details

Please contact us if you have any questions about this product.

Table D-1 Customer Service Contact Details

Country	E-mail	Phone
China	aftersales@whes.com	+86 4008776999

E Abbreviations

A

ACAN **CAN used for communication between MBMU and PCS**

B

BMS **Battery Management System**

C

CSC **Cell Supervision Circuit**

CCAN **CAN used for communication between CSC and SBMU**

CAN **Controller Area Network**

E

ETH **Ethernet Module**

EMS **Energy Management System**

I

IMM **Isolation Monitor Module**

L

LAN **local area network**

M

MCAN **CAN used for communication between SBMU and MBMU**

MSD **Manual Service Disconnect**

S

SOC **state of capacity**

SCAN **CAN used for communication between SBMU and CSU**

U

F Layout Drawing

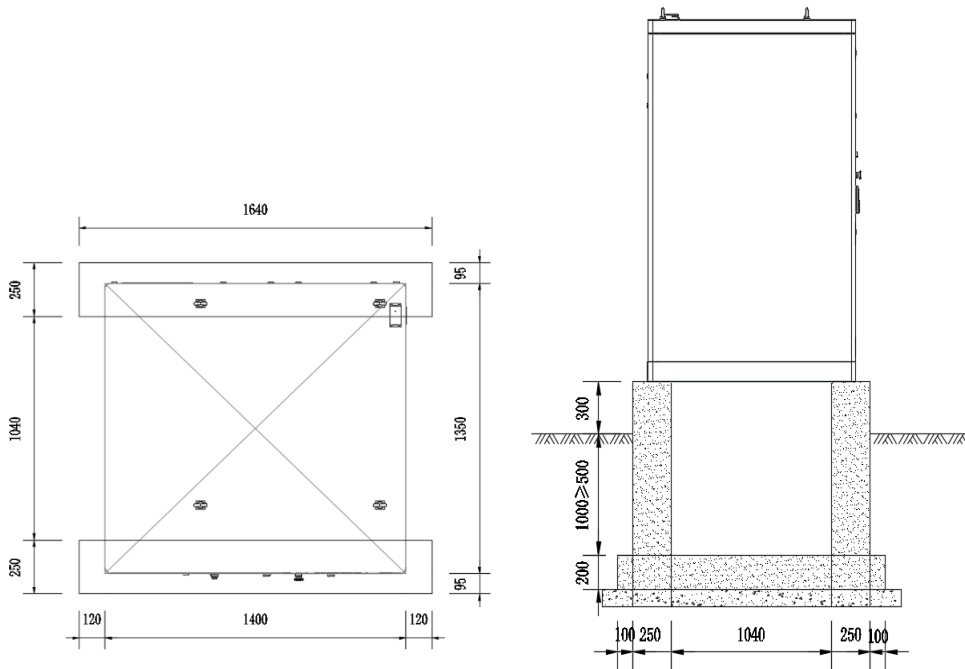

Figure F-1 Concrete foundation sample

Requirements of foundation design scheme :

- a) The energy storage system must be installed on concrete or other non-combustible surfaces. Ensure that the installation plane is level, firm, and smooth, and has sufficient bearing capacity. No sag or tilt is allowed.
- b) The foundation of the device is configured based on the total weight of the device 2.7t. If the bearing capacity of the foundation is insufficient, check it.
- c) The foundation pit bottom of the equipment foundation must be tamped and filled.
- d) Do not disturb the foundation by soaking water after excavation. If the foundation is disturbed by soaking water, continue excavation and replace with filling.

- e) The horizontal error between the contact surface between the base and the cabinet is less than or equal to 3mm.**
- f) The foundation must be above the highest local historical water level and at least 300mm above the level ground.**
- g) Construct drainage facilities based on local geological and municipal drainage requirements to ensure that no standing water is generated at the foundation. The foundation construction should meet the historical maximum rainfall drainage requirements of the local area, and the discharged water should be treated according to local laws and regulations.**
- h) When constructing the foundation, consider that the energy storage system cables are faulty, and reserve trenches or cable inlet holes.**
- i) The reserved holes in the foundation and cable inlet holes at the bottom of the device should be sealed.**
- j) foundation drawings are not to be used as final construction drawings and are for reference only. The user must review the basic design parameters of the energy storage system according to the requirements of the installation environment, geology and earthquake resistance of the project site.**

The following figure shows the minimum installation and O&M space requirements.

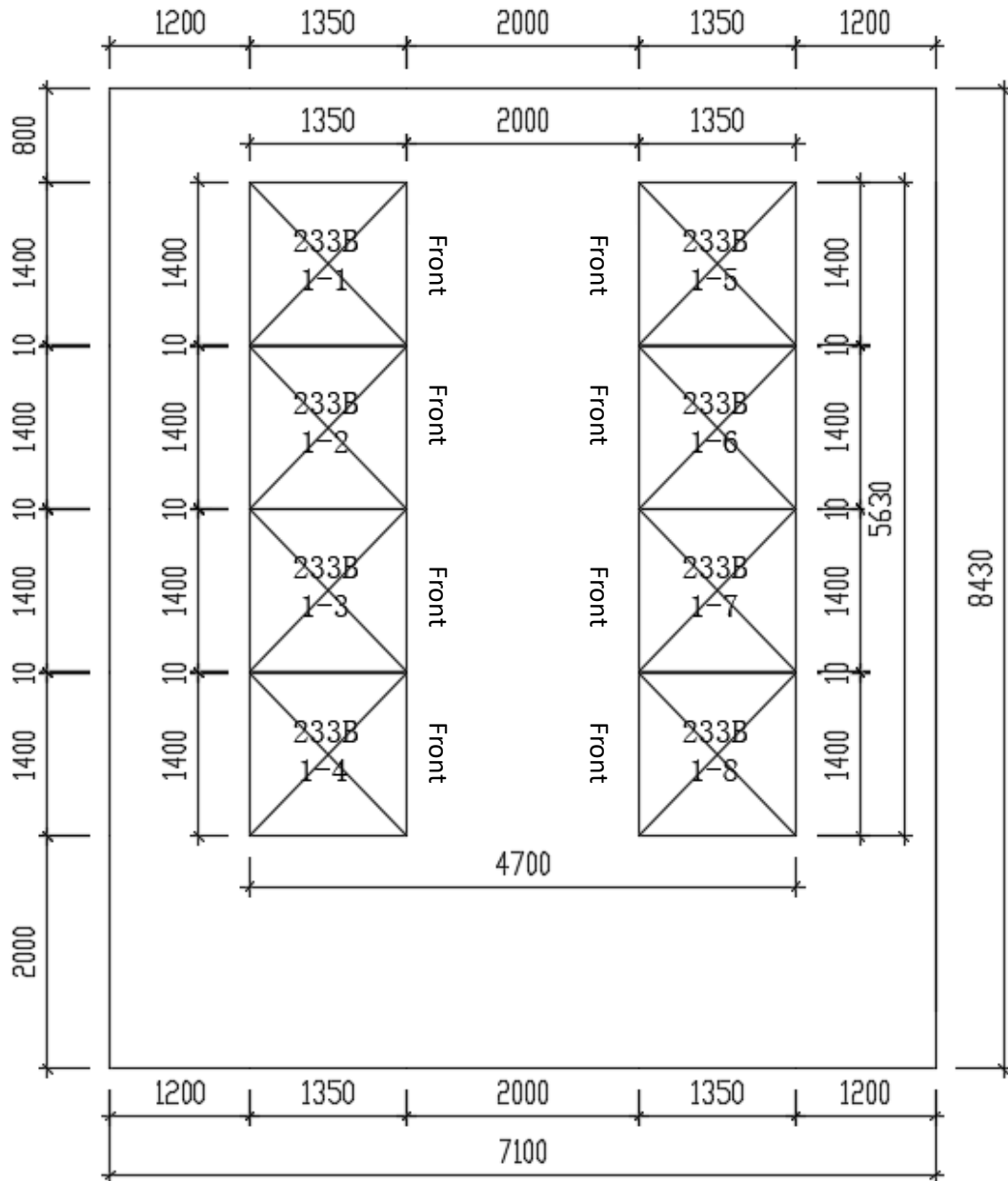

Figure F-2 Installation layout diagram

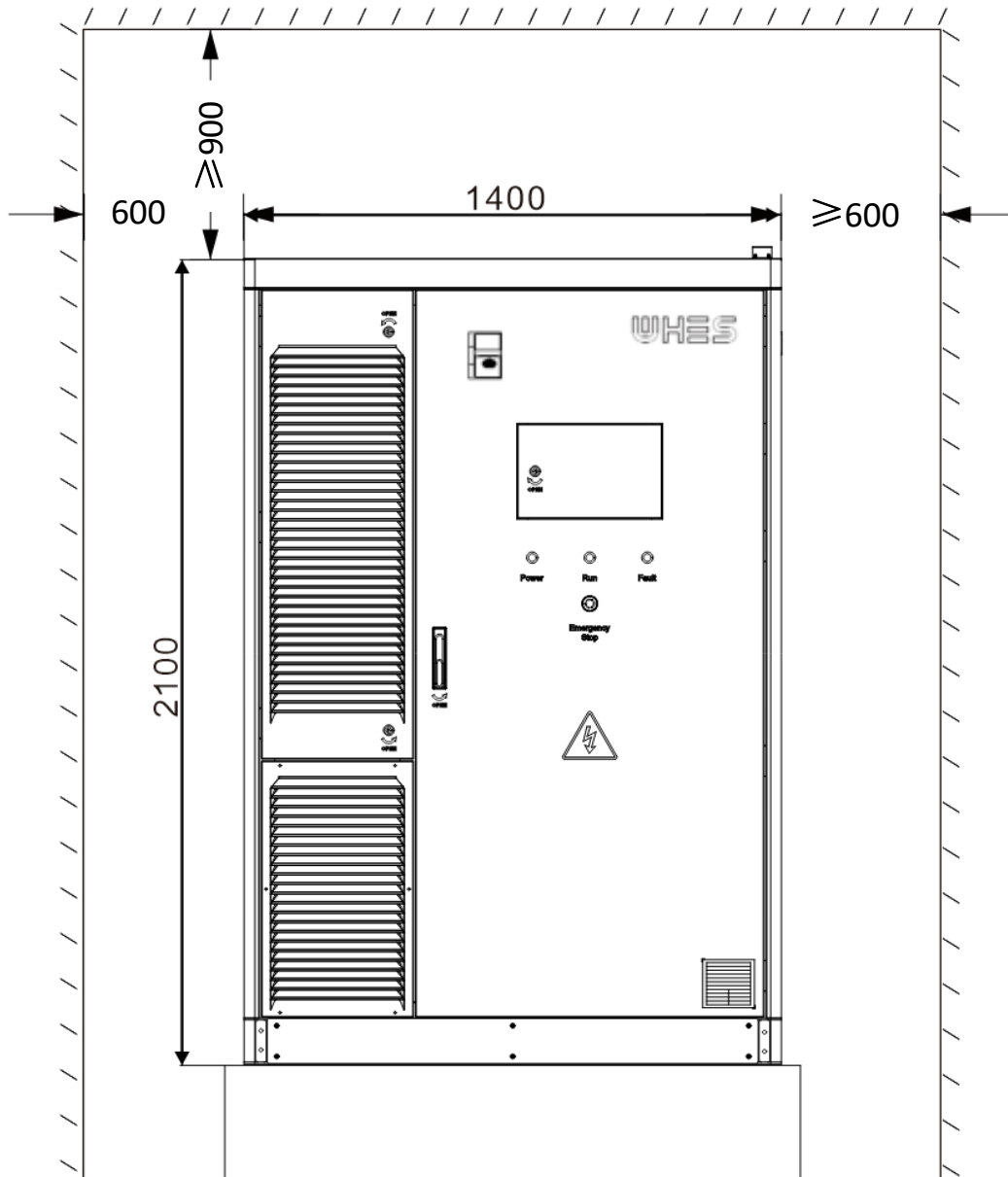

Figure F-3 Front view of floor-mounted installation

i Notice

- Ensure a distance of at least 1M between the installation location of the equipment and the electrical equipment.
- Ensure that a maintenance channel is reserved on one side, with a width of at least 2M.

G Energy Meter Configuration

Voltage and current wiring diagram

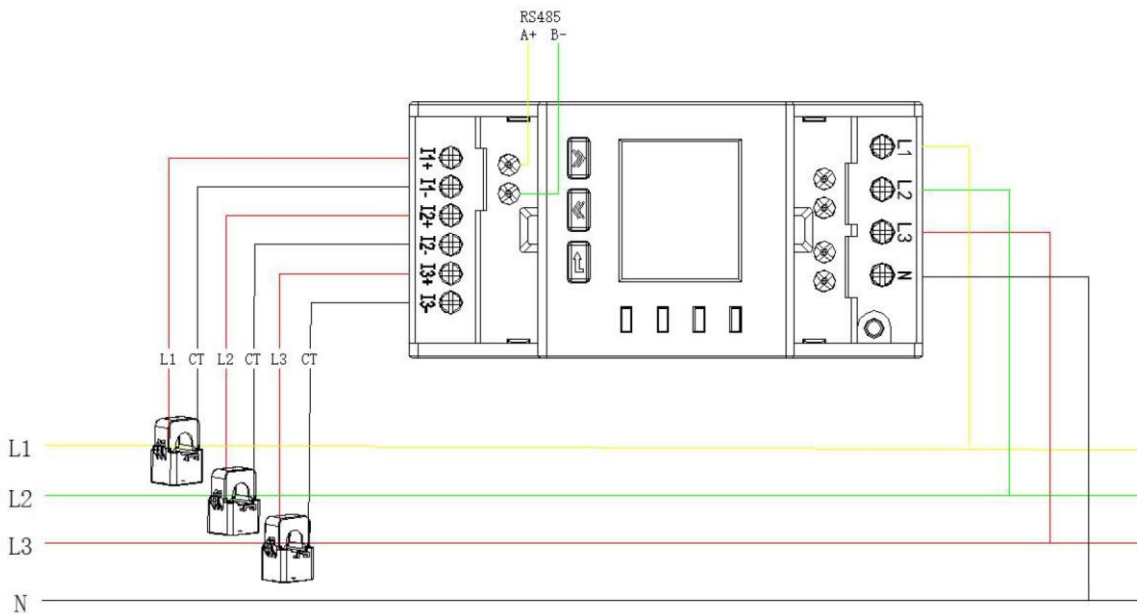

Figure G-1 Voltage and current wiring diagram

Button Function Description





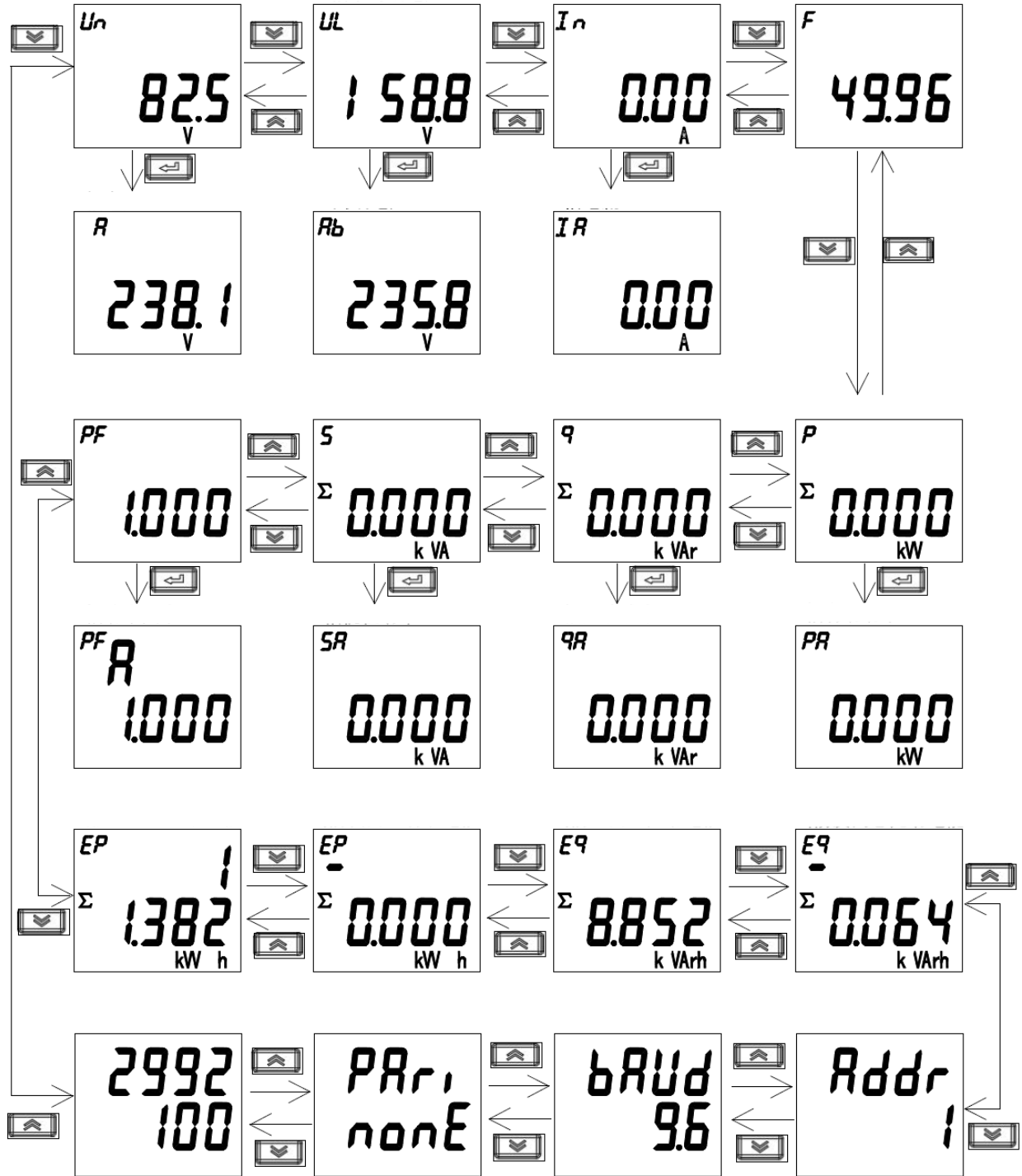

Key icon	key name	key function
	Up key	Switch the interface to the left Left shift and flicker shift in the programming interface
	Down key	Switch the interface to the right Right shift and modify the flicker bit in the programming interface
	Program the determination key	View the sub-menu Determine the save Settings in the programming interface

Display interface

ADL400N:



Programming interface

In any display item under the measurement display menu, long press to  enter the "PASS" interface. The system will prompt for a password (default: 0001). Press  again after inputting. If the password is incorrect, it returns to "0000" for re-entry; if correct, parameter settings become accessible. After completing settings, long press  to enter the "SAVE" interface. Press  to toggle to "YES" then press  to save and exit. Press  under "NO" to exit without saving.

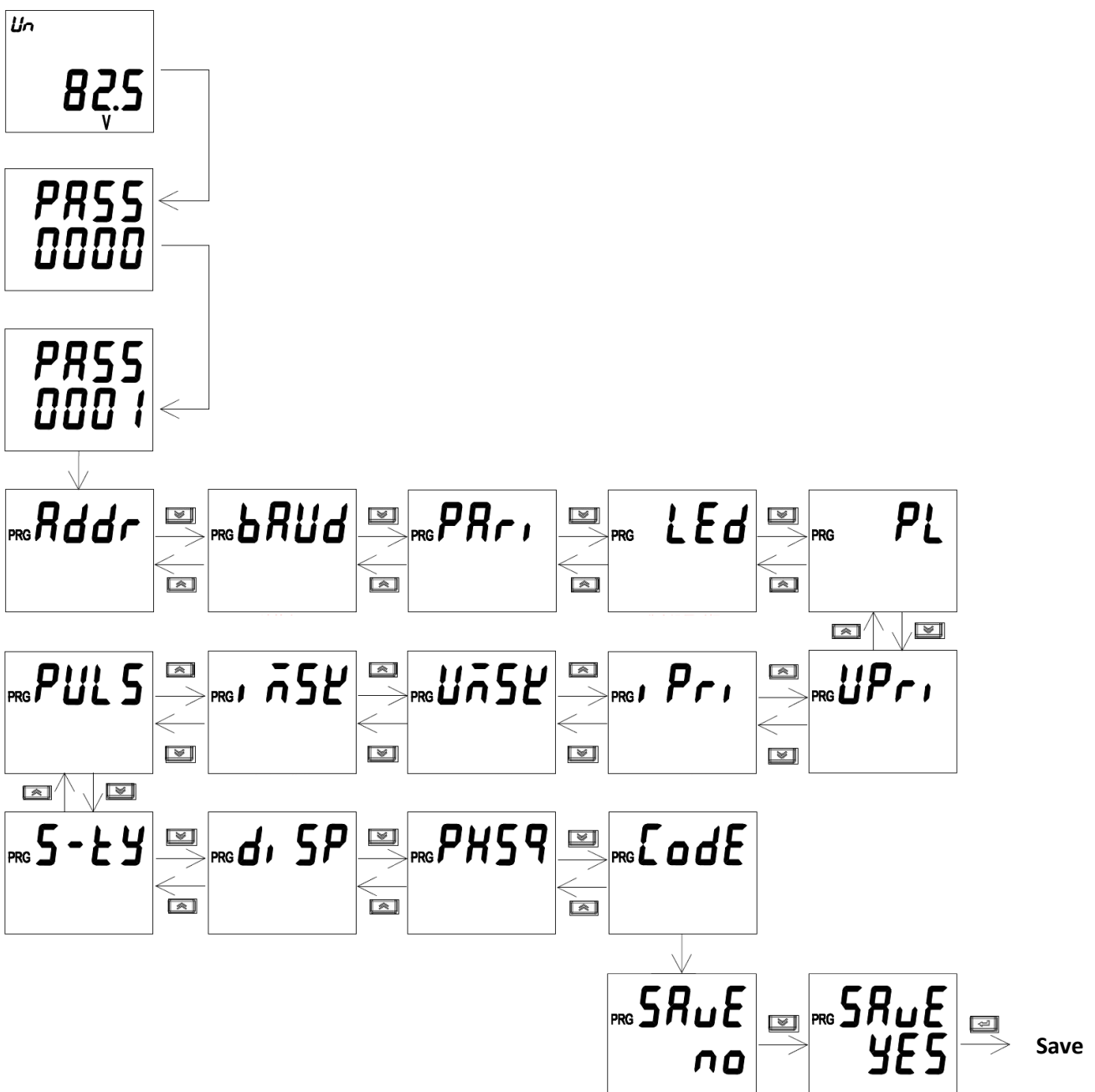

Data items can be set

Symbol	Meaning	Range
Addr	Communication address setting	1-247
bAud	Baud rate selection	38.4: 38400 19.2: 19200 9.6: 9600 4.8: 4800 2.4: 2400 1.2: 1200
PAri	Verification selection	None Even Odd
LEd	Backlight time (reserved)	0-999s
PL	Network selection	3P4L: Three-phase four-wire 3P3L: Three-phase three-wire
UPri	Primary voltage	0.1-9999999.9V
iPri	Primary current	0.01-999999.99A
UMSK	Voltage blocking value	0-99.99%
iMSK	Current blocking value	0-99.99%
PULS	Pulse constant	1-99999
S-ty	Calculation method of apparent power	RMS PQS
diSP	Default interface for power-on	Auto: Automatic wheel display Others: Other interfaces
PHSq	/	/
CoDE	Password setting	1-9999

Technical parameters of the electricity meter

Item	ADL400N-CT
Network	Three-phase four-wire, three-phase three-wire, single-phase three-wire
Rated Voltage	Single-phase: 240/480V; Three-phase: 3×230/400V, 3×277/480V
Overload (Voltage)	1.2×rated value (continuous), 2×rated value for 1 second
Power Consumption (Voltage)	<0.2VA
Accuracy Class (Voltage)	Error ±0.5%
Input Current	80A, 120A, 200A, 300A, 3×80A, 3×120A, 3×200A, 3×300A
Overload (Current)	1.2×rated value (continuous), 2×rated value for 1 second
Power Consumption (Current)	<0.2VA
Accuracy Class (Current)	Error ±0.5%
Power	Active, reactive, apparent power, error ±0.5%
Grid Frequency	45~65Hz, error ±0.5%
Response Speed	≤100ms (voltage, current, power); ≤1s (electric energy)
Electric Energy	Active energy: Class B (open-type transformer)/Class C (closed-type transformer); Reactive energy: Class 2
Electrostatic Discharge Immunity	Class III
Electrical Fast Transient/Burst Immunity	Class IV
Surge (Impact) Immunity	Class IV
Power Frequency Withstand Voltage	AC4kV for 1min between communication and signal inputs
Insulation Resistance	Input and output terminals to case >100MΩ
Interface and Communication Protocol	RS485 port, Modbus RTU protocol
Communication Address Range	Modbus RTU: 1~247
Baud Rate	Supports 1200bps - 38400bps
Operating Temperature	-40°C~+70°C
Storage Temperature	-40°C~+70°C
Relative Humidity	≤95% (non-condensing)
Altitude	≤3000m

Appendix 1

Inspection project	Method	Yes-√ No- × Not applicable-O	Abnormal record
Is the fire extinguishing system	Visual inspection		
Whether the fire extinguishing system is within the validity period	Visual inspection		
Is the cooling system complete	Visual inspection		
Is the cooling system air duct blocked	Visual inspection		
Whether the appearance of the electric cabinet is deformed	Visual inspection		
Whether the appearance of the electric cabinet is rusted or damaged	Visual inspection		
Is there water vapor inside the electric cabinet	Visual inspection		
Whether the LV harness is loose or damaged	Visual inspection		
Whether the HV harness is loose or damaged	Visual inspection		
Whether the wiring harness interferes with the structural parts	Visual inspection		
Whether the high voltage connection is ablated	Visual inspection		
Whether the fixing bolt of structural parts is loose or missing	Visual inspection		
Is MSD complete and reliable	Visual inspection		
Whether the water cooling pipe is damaged	Visual inspection		
Is there a foul smell in the battery compartment	Sniffing		
Is there a pungent smell in the electric cabinet	Sniffing		
Whether HV connection part has burnt smell	Sniffing		
Is the summary data complete	Monitor master computer		
Is the cell voltage data complete	Monitor master computer		
Is the cell temperature data complete	Monitor master computer		
Whether there is an abnormal alarm in the alarm bar	Monitor master computer		
Note: If any abnormalities are found during the inspection, please feedback in time, and contact the relevant personnel for processing.			